



# KLIXON® | S Series (SLA, SDLA, SDLM)

## 35 to 150 Amp Commercial Thermal Circuit Breaker

### FEATURES

- 30VDC, 35 to 150 Amps
- Open and sealed assemblies, manual and automatic reset options
- Ignition protected
- UL Recognized E69772

### DESCRIPTION

The KLIXON® S series thermal breakers are designed to protect wiring and meet the harshest environmental requirements. The sealed circuit breakers are weatherproof for protection against moisture, dust, grease, fuel vapors and other harsh environments. The S series breakers are lightweight and designed to interrupt short circuits or overloads and combine trip-free protection with fast response time. Typical applications are protection of wire and cable of accessory circuits, equipment and battery protection on heavy trucks, buses, construction equipment, off-road vehicles, marine, recreational vehicles (RVs) and electric (hybrid) vehicles, and battery chargers.

The S series is available in both open and sealed body configurations with manual and automatic reset options.

### ORDERING INFORMATION

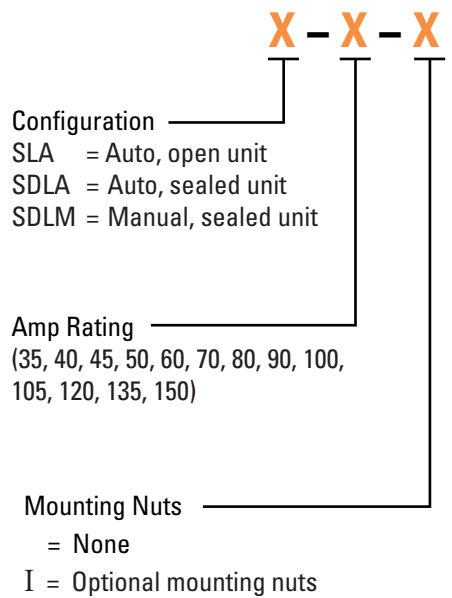

### PERFORMANCE CHARACTERISTICS

Calibration : 200% rated current, 77°F (25°C)	35 to 150 Amps : 8 to 100 seconds
Ultimate Trip At 77°F (25°C)	Must hold 100%, Must trip 135%
Endurance	Per SAE J1625
Interrupt Current Capacity	Per SAE J1625 and ABYC E-11
Mechanical Vibration	Per SAE J1455, 4G's, 10-2K Hz
Voltage Breakdown	Per SAE J1625 500VAC
Salt Spray	Per SAE J1625, 96 hours
Voltage Drop	Per SAE J1625
Weight (with mounting nuts)	SDLM (A) : 75 grams (71 grams) max SLA : 62 grams max

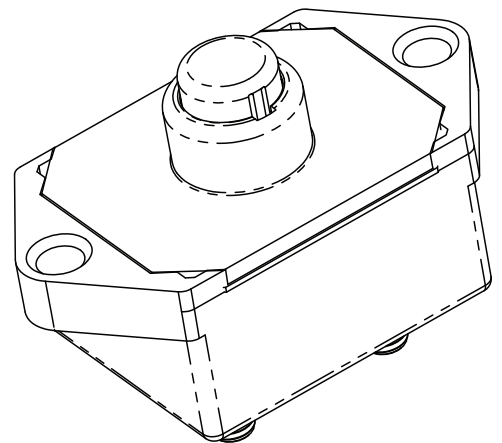

## TRIP CURVE - Approximate Time, Current Characteristics At 77°F (25°C)

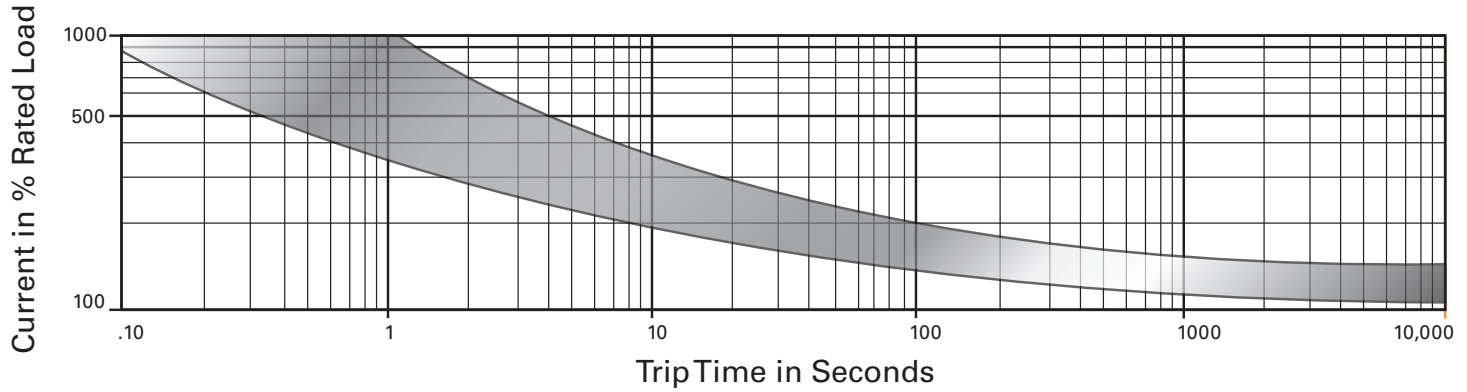

## DIMENSIONS - SDLM

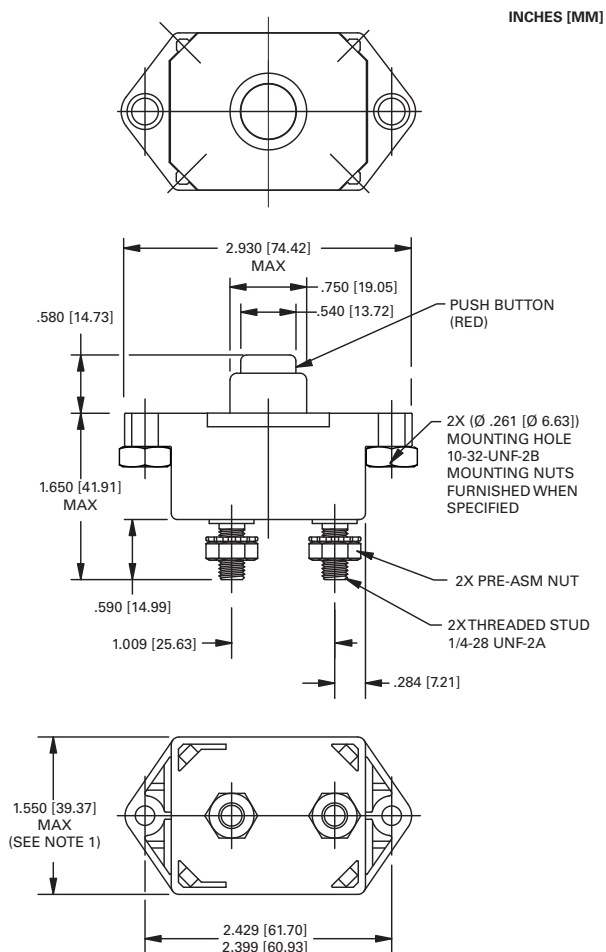

## DERATING CURVE

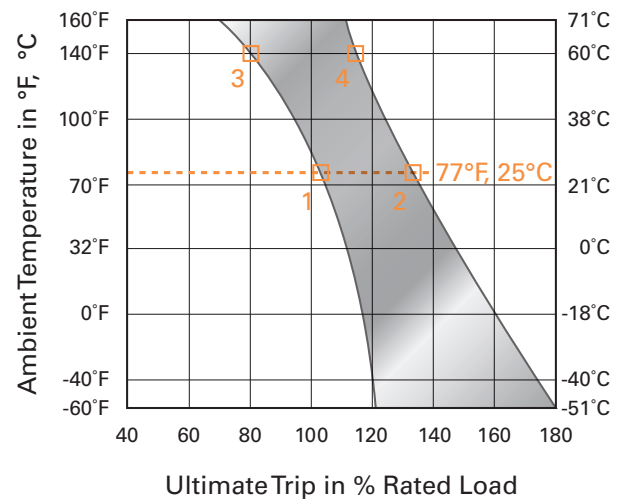

Performance characteristics are based on room temperature (77°F, 25°C). Consult Derating curve for ambient temperatures significantly higher or lower than standard room temperature.

*Example:* At 77°F (25°C) the device is calibrated to hold at 100% of rated current (1) and trip at 135% of rated current (2). At 140°F (60°C), the same device will hold at approximately 78% of rated current (3), and trip at approximately 115% of rated current (4).

### Notes:

1. Dimension does not include sealing gasket.