



# SCM54E

## SWITCHING POWER, DIGITAL PROCESSING

### BATTERY BUS CHARGER/MAINTAINER

=====

#### Specification:

**Charges----- 12V SLI, AGM, Gel Batteries**  
**Input-----220-240VAC 2A 50HZ**  
**Charging Output Mode-----5 AMPS**  
**Maintenance Output Mode-----Pulse Charge**  
**Leads-----183 CM**  
**Size-----35.0 X 19.0 X 7.5 CM**  
**Weight-----2.5KGS**

# SCM54E SWITCHING POWER, DIGITAL PROCESSING BATTERY CHARGER/MAINTAINER

---

## **IMPORTANT SAFETY INSTRUCTIONS :**

1. **SAVE THESE INSTRUCTIONS** – This manual contains important safety and operating instructions for battery charger/maintainer Model SCM54E.
2. Use SCM54E only on 12 volts LEAD ACID, AGM and GELLED ELECTROLYTE (GEL-CELL) batteries. Do not attempt to use on other voltages and types of batteries (DRY CELL, NICKEL CADMIUM, NICKEL METAL HYDRIDE, etc.) commonly found in small home appliances. This may cause SCM54E and batteries to burst, resulting in damage or injury to person and property. SCM54E delivers up to 5 Amps.
3. Do not expose SCM54E to direct sunlight, rain or snow.
4. Do not use SCM54E on batteries that are in use or that are installed. If necessary to remove batteries from the vehicle and take to a properly installed SCM54E location.
5. Do not use attachments with the SCM54E that are not recommended. Non-recommended attachments may result in injury, electric shock, or fire and voids the warranty.
6. To reduce risk of damage to electric plug and cord, pull by plug rather than cord when disconnecting charger.
7. An extension cord should not be used unless absolutely necessary. Use of improper extension cord could result in a risk of fire and electric shock.
8. Do not operate charger with damaged cord or plug – replace the cord or plug immediately.
9. Do not operate charger if it has received a sharp blow, been dropped, or otherwise damaged in any way; take it to a qualified serviceman.
10. Do not disassemble charger; take it to a qualified serviceman when service or repair is required. Incorrect reassembly may result in a risk of electric shock or fire
11. To prevent injury during cleaning or maintenance, disconnect all batteries and move them to clear access to the unit. Unplug SCM54E from the wall outlet. Use a slightly dampened cloth to clean the housing and lead sets. Do not use solvents or soaps.

12. Place the power cords in a location where they will not be stepped on, tripped over, or subjected to stress or abuse of any kind.
13. For fuse replacement, contact distributors for replacement. Any tampering or incorrect assembly may result in fire or electric shock and voids the warranty.
14. Never attempt to charge a frozen battery. Allow the battery to return to room temperature before connection. Suggested operation range is in ambient temperature.
15. Never use SCM54E in or on any boat or watercraft. You must remove the battery from the boat or watercraft and charge the battery at the properly installed location of SCM54E unit.
16. Do not install SCM54E where it will be exposed to moisture or inclement weather, or around combustibles like trash, flammable liquids and vapors.

## **WARNING -- RISK OF EXPLOSIVE GASES**

1. WORKING IN THE VICINITY OF A LEAD ACID BATTERY IS DANGEROUS. BATTERIES GENERATE EXPLOSIVE GASES DURING NORMAL BATTERY OPERATION. FOR THIS REASON, IT IS OF UTMOST IMPORTANCE THAT EACH TIME BEFORE USING YOUR SCM54E, YOU READ THIS MANUAL AND FOLLOW THE INSTRUCTIONS EXACTLY.
2. To reduce risk of battery explosion, follow these instructions and those published by the battery manufacturer and manufacturer of any equipment you intend to use in the vicinity of the battery. Observe cautionary markings on these items.

## **PERSONAL SAFETY PRECAUTIONS :**

1. Someone should be within range of your voice or close enough to come to your aid when you work near a lead acid battery.
2. Have plenty of fresh water and soap nearby in case battery acid contacts skin, clothing or eyes.
3. Wear complete eye protection and protective clothing.
4. Avoid touching eyes while working near battery.
5. If battery acid contacts skin or clothing, wash immediately with soap

and water. If acid enters eye, immediately flood eye with running cold water for at least ten minutes and get medical attention immediately.

6. NEVER smoke or allow a spark or flame in vicinity of battery or engine.
7. Be extra cautious to reduce risk of dropping a metal tool onto the battery. It could spark or short-circuit the battery or other electrical parts and could cause an explosion.
8. Remove personal metal items such as rings, bracelets, necklaces and watches when working with a lead acid battery. It can produce a short circuit current high enough to weld a ring or the like to metal causing a severe burn.

### **PREPARING TO CHARGE :**

1. Be sure area around battery is well ventilated while battery is being charged. Gas can be forcefully blown away by using a piece of cardboard or other nonmetallic material as a fan.
2. Clean battery terminals. Be careful to keep corrosion from coming in contact with eyes.
3. Inspect the battery for cracked or broken case or cover. If battery is damaged, do not use charger.
4. If the battery is not sealed maintenance free, add distilled water in each cell until battery acid reaches level specified by the manufacturer. This helps purge excessive gas from cells. Do not overfill. For a battery without cell caps, carefully follow manufacturer's recharging instructions.
5. If necessary to remove battery from vehicle to charge, always remove ground terminal from battery first. Make sure all accessories in the vehicle are off to ensure you do not cause any arcing.
6. Study all battery manufacturer's specific precautions such as removing or not removing cell caps while charging and recommended rates of charge.
7. Determine voltage of battery by referring to car owner's manual and make sure it matches output rating of battery charger.
8. If the battery and terminals have a white or bluish crust on them, the charging system may be having problem. These problems should be

corrected before the battery is replaced after charging.

### **CHARGER/MAINTAINER LOCATION:**

1. Locate charger as far away from battery as DC cables permit.
2. Never place charger directly above battery being charged. Gases from battery will corrode and damage charger.
3. Never allow battery acid to drip on charger when reading gravity or filling battery.
4. Do not operate charger in a closed area or restrict ventilation in any way.
5. Do not set a battery on top of charger.

### **SETTING UP & OPERATIONS:**

1. Make sure the room has plenty of ventilation.
2. Mount SCM54E away from any vehicle repair or service. Make sure never to start or run an engine near the batteries being charged.
3. Be sure the total amperage used by SCM54E should not exceed the amperage capacity of the supply source. If you do not know how to determine this, have a qualified electrician determine the capacity for you.
4. Connect and disconnect DC output clips only after removing AC cord from electric outlet. Never allow clips to touch each other.
5. Make sure the battery terminals are clean. Wire brush them if necessary. Clamp the black lead to the negative battery terminal. Clamp the red lead to the positive battery terminal.
6. Connect SCM54E to a grounded power receptacle that is wired in compliance with local electrical codes.

※Side mounted batteries will require the insertion of a lead post adapter. Plain bolts are not safe. They will not allow for accurate reading and should not be used.

7. After plugging the AC cord, please turn on the power switch to start SCM54E.

8. When SCM54E is being used, it will show LED lights as follows:  
**Green and red LED light both off: NO AC Power**  
There is no AC power applied.

**Green light flashing only: Standby for charging batteries**

Before using, please check following:

- a. Are clamps properly connected to batteries?
- b. Is the battery voltage below 1 voltage?
- c. Is there any battery under charge?

**Green light on & red light flashing: Charging batteries**

SCM54E is charging the batteries.

**Red light on only: Defective battery or deeply discharged battery**

Please make sure again the battery posts and clamps are all clean.

If the red light continues:

- a. Check if the batteries are 12V battery or not.
- b. If yes, the battery does not hold a charge. It should be replaced immediately.
- c. Or it needs more time to charge deeply discharged battery.

If the red light still lightens after 20 hours charging, please replace the battery.

**Green light & red light both on : 75% Charged**

The battery is at least 75% charged and is ready to load test or can be returned to serve. Continued charging will get the battery to be fully charged.

※Some battery will pass and accept a charge, but will not be able to pass a load test. All batteries should be load tested after charging.

**Green light on only : Batteries is fully charged and is under maintaining**

It will automatically adjust the voltage/current relationship to maintain the battery at a full charge. The battery is ready for a load test or return to serve. If the battery voltage drops below 12.8 volts, SCM54E shifts automatically into charging mode and recharges to an OCV of 14.8 volt.

9. Disconnecting a battery from SCM54E :

SCM54E is safely maintaining the battery at a full charge when the green light is on. The battery is ready. Simply remove the battery clamps and set them on the working surface clear from the other batteries and battery clamps. You can now load test the battery if necessary.

- ※ 1. When the battery clamps are accidentally disconnected while charging is in effect, the SCM54E will shut off. Green indicator light will go flashing. Simply reconnect the battery charged.
- 2. Do not disconnect the battery while charging at 5Amps. Wait for both green and red LED light on.

10. If you would like to charge 4 pieces of 12V battery in series connection, please connect SCM54A/E stations to the batteries as the drawing below:

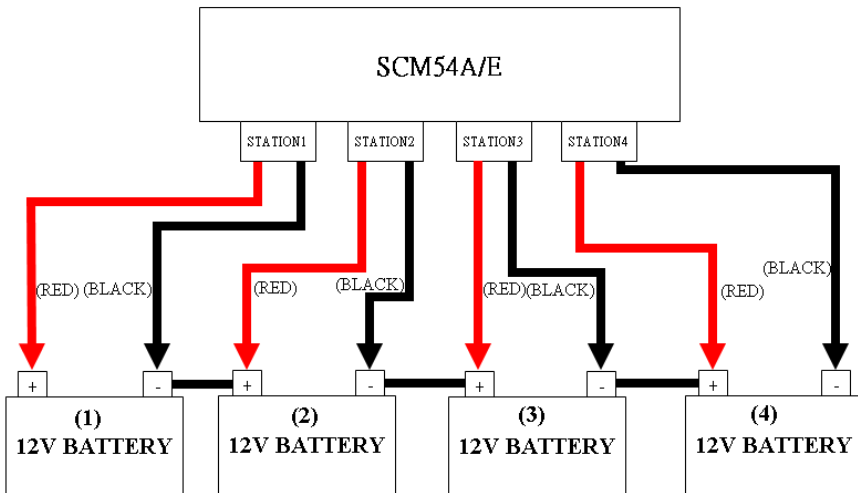

**NOTE:**

- 1. Each station of SCM54E can only be connected to one battery.
- 2. Never connect one station to two or more different batteries.
- 3. Please refer to the drawing below.

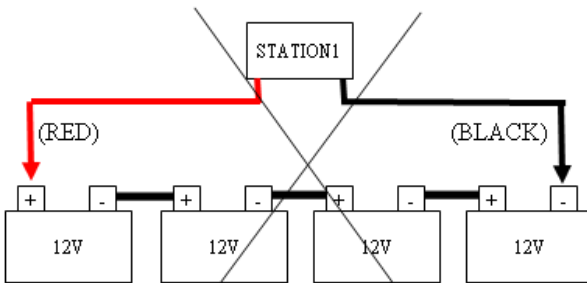
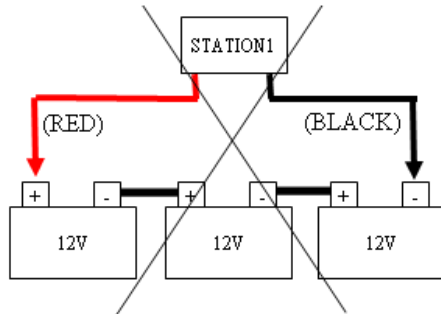
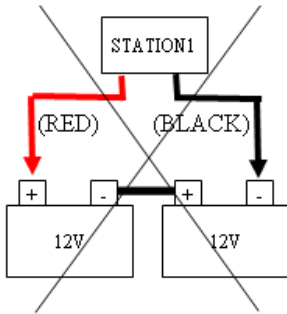

1. Congratulation:

DHC has developed its own advanced processes and has applied advanced technology to the development of the SCM54E Switching Power, Digital Processing Battery Charger.

SCM54E Professional Charger provides 5 Stage Automatic, True Pure DC current charging capacity, which **not only will charge a battery efficiently, but will also prolong the lifetime of the requisite battery.**

## 2. Why do we offer 5 Stage Charging?

### The voltage/current curve graph

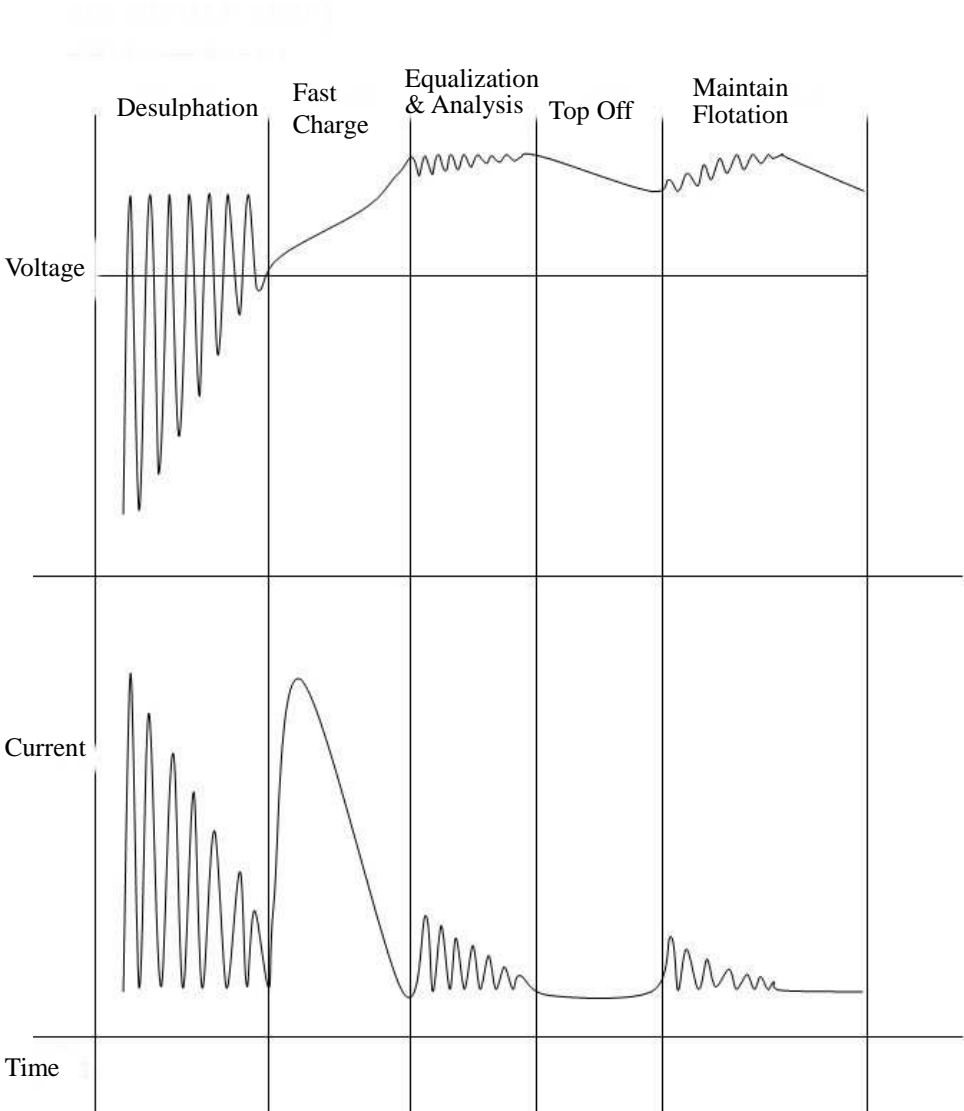

### 1<sup>st</sup> Stage: Desulfation:

Focused on deeply discharged or lightly sulfated batteries, which show low voltage and are hard to activate. The SCM54E Charger will start the charge pulse to charge the battery until the voltage recovers & reaches expected rechargeable level. The purpose of this stage is **to save an over-discharged or a lightly sulfated battery for recovery.**

### 2<sup>nd</sup> Stage: Fast Charge:

When the voltage of the battery is above the set level. The SCM54E Charger carries a high current to charge the battery quickly until the battery is returned to 75% of the charge. The purpose of this stage is **to charge battery in the fastest and most efficient manner.**

### 3<sup>rd</sup> Stage: Equalization & Analysis:

When the voltage reaches a maximum safe (pre-determined) voltage, The SCM54E will discontinue the Fast Charge automatically & start a charge pulse with a smaller steam current to charge the battery. The purpose of this stage is **to fully charge the battery in safe manner.**

### 4<sup>th</sup> Stage: Top-Off Charge:

Under this stage, the SCM54E Charger will shut off automatically when the battery is 100% charged. The charger will monitor the battery voltage continually to decide whether a new charge pulse should come. The purpose of this stage is **to fully charge the battery without overcharging the battery.**

### 5<sup>th</sup> Stage: Maintain Floating:

If the voltage drops below the pre-set level by battery self-discharge, the SCM54E Charger starts a charge pulse with a small current **to maintain the battery in full-charge status.** The cycle is repeated as long as the charger is in “Maintain Floating” mode.

## **FAST CHARGE TIME**

<b>Battery Size (Ah)</b>	<b>5 Amp Time to 75% Charge (h)</b>
10	2
14	2-3
20	4
50	10
90	18
120	24
150	30
200	40

### 3. Other advantages of SCM54E Charge

**Energy Saving:** The SCM54E Charger provides True Pure DC current Charging capacity which reduce power consumption in charging process & **save up to 20% energy** compared to conventional chargers.

**Time Saving:** Switching mode technology charges battery at least **1.5 times faster** than units using conventional technology.

**Safe: Reverse hook-up/Sparking protection; Overcharging protection, and Short circuit protection.**

**Easy: Bright LED lights** identify the charging status exactly.

**Light: Portable & compact.**

## **TERMS AND CONDITIONS OF WARRANTY**

Any battery charger defective in material or workmanship will be repaired or replaced according to published defective return test repair procedures. The existence of a defect shall be determined by the seller in accordance with published procedures. The published test procedures are available upon request.

This warranty does not cover any unit that has been damaged due to accident, abuse, alternation, use for a purpose other than that for which it was intended, or failure to follow operating instructions. This warranty is expressly limited to original retail buyers. This warranty is not assignable or transferable. Proof of purchase is required for all alleged claims. Warranty cannot be authorized without proof of purchase. Warranty claims must be sent pre-paid with dated proof of purchase. Damage incurred during shipment is the responsibility of the shipper (customer returning unit) If the returned unit qualifies for warranty, the shipper will only incur shipping cost. The seller reserves the right to substitute or offer alternative warranty options at its discretion.

The sole and exclusive remedy for any unit found to be defective is repair or replacement, at the option of the seller. In no event shall the seller be liable for any direct, indirect, special, incidental, or consequential damages (including lost profit) whether based on warranty, contract, tort, or any other legal theory.

### **RETURN GOODS:**

Pack with sufficient over-pack to prevent damage during shipment. Damage incurred during return shipment is not covered under this warranty. Repair costs for such damages will be charged back to shipper.

### **REMARK:**

**WHEN RETURNING GOODS, PLEASE SHOW “RETURN GOODS” ON ALL INVOICES & RELATED SHIPPING DOCUMENTS TO PREVENT ANY EXTRA CHARGE.”**