



THE UNITED KINGDOM VEHICLE APPROVAL AUTHORITY

COMMUNICATION CONCERNING THE ~~APPROVAL GRANTED<sup>(4)</sup>~~ / APPROVAL EXTENDED<sup>(1)</sup> /  
~~APPROVAL REFUSED<sup>(4)</sup>~~ / ~~APPROVAL WITHDRAWN<sup>(4)</sup>~~ / PRODUCTION DEFINITELY  
~~DISCONTINUED<sup>(4)</sup>~~ OF A TYPE OF DEVICE PURSUANT TO REGULATION NO. 7.02



Approval No: 07R-026796

Extension No: 01

1. Trade name or mark of the device: Speaker or **J.W. SPEAKER** →
2. Manufacturer's name for the type of device: Model 8700 (RHT) EVO<sub>2</sub>-S, EVOJ-2
3. Manufacturer's name and address:  
J.W. Speaker Corporation  
N120 W19434 Freistadt Road  
P.O. Box 1011  
Germantown, WI 53022-8211  
U.S.A.
4. If applicable, name and address of the manufacturer's representative: not applicable
5. Submitted for approval on: as before and 2 March 2017
6. Technical service responsible for conducting approval tests: Vehicle Certification Agency
7. Date of report issued by that service: as before
8. Number of report issued by that service: as before

UST389409



9. Concise description: front position

9.1. By category of lamp: A incorporated in a headlamp

For mounting either outside ~~or inside or both~~:<sup>(4)</sup>

Colour of light emitted: ~~RED~~/ WHITE<sup>(1)</sup>

Number, category and kind of light source(s): 2, LED

Voltage and wattage: 12/24V, 2.0W

Light source module specific identification code: 3454640 (EVOJ-2), 3454320 (EVO2-S) non-replaceable

Only for limited mounting height of equal to or less than 750 mm above the ground:  
~~YES~~/NO<sup>(1)</sup>

Geometrical conditions of installation and relating variations, if any: refer to manufacturer's documentation

9.2 Function(s) produced by an interdependent lamp forming part of an interdependent lamp system:

Front position lamp	<del>YES</del> / NO <sup>(1)</sup>
R1 Rear position lamp	<del>YES</del> / NO <sup>(1)</sup>
R2 Rear position lamp	<del>YES</del> / NO <sup>(1)</sup>
S1 Stop lamp	<del>YES</del> / NO <sup>(1)</sup>
S2 Stop lamp	<del>YES</del> / NO <sup>(1)</sup>
S3 Stop lamp	<del>YES</del> / NO <sup>(1)</sup>
S4 Stop lamp	<del>YES</del> / NO <sup>(1)</sup>
End-outline marker lamp	<del>YES</del> / NO <sup>(1)</sup>

10. Position of the approval mark: outer lens, top center

11. Reason(s) for extension (if applicable): Added part numbers

12. Approval ~~GRANTED/REFUSED~~/ EXTENDED ~~WITHDRAWN~~:<sup>(1)</sup>

13. Place: BRISTOL



14. Date: 30 MARCH 2017

15. Signature:  D LAWLOR  
Head of Technical Standards & Legislation

16. The list of documents deposited with the Administrative Service which has granted approval is annexed to this communication and may be obtained on request.

Any remarks: Approval to Supplement 22  
Component Number(s): 0552760, 0553320, 0553980, 0554550

(1) Strike out what does not apply





THE UNITED KINGDOM VEHICLE APPROVAL AUTHORITY

COMMUNICATION CONCERNING THE ~~APPROVAL GRANTED<sup>(4)</sup>~~/ APPROVAL EXTENDED<sup>(1)</sup>/  
~~APPROVAL REFUSED<sup>(4)</sup>~~/ ~~APPROVAL WITHDRAWN<sup>(4)</sup>~~/ PRODUCTION DEFINITELY  
~~DISCONTINUED<sup>(4)</sup>~~ OF A TYPE OF DAYTIME RUNNING LAMP PURSUANT TO REGULATION NO:  
87



Approval No: 87R-006796

Extension No: 01

1. Trade name or mark of the daytime running lamp: Speaker or **J.W. SPEAKER** 
2. Manufacturer's name for the type of daytime running lamp: Model 8700 (RHT) EVO<sub>2</sub>-S, EVOJ<sub>2</sub>
3. Manufacturer's name and address:  
J.W. Speaker Corporation  
N120 W19434 Freistadt Road  
P.O. Box 1011  
Germantown, WI 53022-8211  
U.S.A.
4. If applicable, name and address of the manufacturer's representative: not applicable
5. Submitted for approval on: as before and 2 March 2017
6. Technical service responsible for conducting approval tests: Vehicle Certification Agency
7. Date of test report issued by that service: as before
8. Number of test report issued by that service: as before

UST389409



9. Concise description: daytime running lamp

By category of lamp: RL

Number, category and kind of light source(s): 2, LED <sup>(2)</sup>

Voltage and wattage: 12 / 24 V, 19W

Application of an electronic light source control gear:

- being part of the lamp YES/~~NO~~ <sup>(4)</sup>
- being not part of the lamp ~~YES~~/NO <sup>(1)</sup>

Input voltage supplied by an electronic light source control gear: not applicable

Electronic light source control gear manufacturer and identification number (when the light source control gear is part of the lamp but is not included into the lamp body: not applicable

10. The daytime running lamp is designed as an interdependent lamp system ~~YES~~/NO <sup>(1)</sup>

The interdependent lamp system consists of ~~2/3~~ <sup>(4)</sup> interdependent lamps.

11. Position of the approval mark: outer lens, top center

12. Reason(s) for extension (if applicable): added part numbers

13. Approval ~~GRANTED~~/ EXTENDED /~~REFUSED~~/~~WITHDRAWN~~ <sup>(4)</sup>

14. Place: BRISTOL

15. Date: 30 MARCH 2017

16. Signature:  D LAWLOR  
Head of Technical Standards & Legislation

17. The following documents, bearing the approval number shown above, are available on request:

Any remarks: Approval to Supplement 17  
Component Number(s): 0552760, 0553320, 0553980, 0554550

(1) Strike out what does not apply.

(2) For daytime running lamps with non-replaceable light sources indicate the number and total wattage of the light sources used.





THE UNITED KINGDOM VEHICLE APPROVAL AUTHORITY

COMMUNICATION CONCERNING THE ~~APPROVAL GRANTED<sup>(4)</sup>~~/ APPROVAL EXTENDED<sup>(1)</sup>/  
~~APPROVAL REFUSED<sup>(4)</sup>~~/ ~~APPROVAL WITHDRAWN<sup>(4)</sup>~~/ ~~PRODUCTION DEFINITELY~~  
~~DISCONTINUED<sup>(4)</sup>~~ OF A TYPE OF HEADLAMP PURSUANT TO REGULATION NO 112.01



Approval No: 112R-016796

Extension No: 01

1. Trade name or mark of the device: Speaker or **J.W. SPEAKER** 
2. Manufacturer's name for the type of device: Model 8700 (RHT) EVO<sub>2</sub>-S, EVOJ-2
3. Manufacturer's name and address:  
J.W. Speaker Corporation  
N120 W19434 Freistadt Road  
P.O. Box 1011  
Germantown, WI 53022-8211  
U.S.A.
4. If applicable, name and address of manufacturer's representative: not applicable
5. Submitted for approval on: as before and 2 March 2017
6. Technical service responsible for conducting approval tests: Vehicle Certification Agency
7. Date of report issued by that service: as before
8. Number of report issued by that service: as before

9. Brief description: Passing and Driving Beam

Category as described by the relevant marking: HCR PL <sup>(2)</sup>

Number and category(s) of filament lamp(s): not applicable

Reference luminous flux used for the principal passing beam (lm): not applicable

Principal passing beam operated at approximately (V): not applicable

Measures according to paragraph 5.8. of this Regulation: (b) Downward adjustment of the beam.

Number and specific identification code(s) of LED module(s) and for each LED module a statement whether it is replaceable or not: ~~YES~~/NO <sup>(1)</sup>.

Number: 1 module(s); passing beam – 3, LED; driving beam – 6, LED

Specific identification code: PCB 3454320 (Model 8700 EVO2-S), PCB 3454640 (Model 8700 EVOJ-2); non-replaceable

Number and specific identification code(s) of electronic light source control gear(s): part of the lamp

Total objective luminous flux as described in paragraph 5.9. exceeds 2,000 lumen: ~~YES~~/ NO /~~DOES NOT APPLY~~ <sup>(4)</sup>.

The adjustment of the cut-off has been determined at: 10 m/~~25 m/does not apply~~ <sup>(4)</sup>.

The determination of the minimum sharpness of the "cut-off" has been carried out at: ~~10 m/25 m/does not apply~~ <sup>(1)</sup>

10. Approval mark position: outer lens, top center

11. Reason(s) for extension of approval: added part numbers

12. Approval ~~GRANTED~~ / EXTENDED / ~~REFUSED~~ / ~~WITHDRAWN~~ <sup>(4)</sup>

13. Place: BRISTOL

14. Date: 30 MARCH 2017

15. Signature:



D LAWLOR  
Head of Technical Standards & Legislation

16. The list of documents deposited with the Administrative Service which has granted approval is annexed to this communication and may be obtained on request.

Any remarks: Approval to Supplement 5  
 Maximum Luminous Intensity: 17.5  
 Rated voltage: 12V / 24V  
 Rated wattage: Passing Beam: 24W  
 Driving Beam 45W

Component Number(s): 0552760, 0553320, 0553980, 0554550

(1) Strike out which does not apply.

(2) Indicate the appropriate marking selected from the list below:

- |          |          |          |        |        |        |        |         |         |       |       |
|----------|----------|----------|--------|--------|--------|--------|---------|---------|-------|-------|
| C,       | C,       | C,       | R,     | R PL   | CR,    | CR     | CR,     | C/R,    | C/R,  | C/R,  |
|          | -->      | <-->     |        |        |        |        | <-->    |         | -->   | <-->  |
| C/,      | C/,      | C/,      | C PL,  | C PL,  | C PL,  | CR PL, | CR PL   | CR PL   |       |       |
|          | -->      | <-->     |        | -->    | <-->   |        | -->     | <-->    |       |       |
| C/R PL   | C/R PL   | C/R PL   | C/PL   | C/PL   | C/PL   |        |         |         |       |       |
|          | -->      | <-->     |        | -->    | <-->   |        |         |         |       |       |
| HC,      | HC,      | HC,      | HR,    | HR PL, | HCR,   | HCR,   | HCR,    | HC/R,   | HC/R, | HC/R, |
|          | -->      | <-->     |        |        |        |        | <-->    |         | -->   | <-->  |
| HC/,     | HC/,     | HC/,     | HC PL, | HC PL, | HC PL, | HCR PL | HCR PL, | HCR PL, |       |       |
|          | -->      | <-->     |        | -->    | <-->   |        | -->     | <-->    |       |       |
| HC/R PL, | HC/R PL, | HC/R PL, | HC/PL, | HC/PL, | HC/PL, |        |         |         |       |       |
|          | -->      | <-->     |        | -->    | <-->   |        |         |         |       |       |



**APPROVAL OF A TYPE OF FRONT AND REAR POSITION LAMPS,  
 STOP LAMPS AND END-OUTLINE MARKER LAMPS PURSUANT TO  
 REGULATION NO 07.02**

Approval Number Issued: 6796

Extension No.: 01

CHANGES FROM THE ORIGINAL CERTIFICATION			
Date	Rev	Author's Initials	Changes
8/15/16	o	MJH	Initial Approval
2/1/17	01	MJH	Added Model 8700 EVOJ2, part number 0553980 and 0554550

Group Approval: Yes

If yes, list the Regulations included in the group approval: Reg. 112, Reg. 7, Reg. 87

Trade name or mark of the device: Speaker

Manufacturer's name for the type of device: 8700 EVO2-S, 8700 EVOJ2

Component(s) to be covered by approval: 0552760, 0553320, 0553980, 0554550

Is the lamp vehicle specific: No

If yes, Vehicle manufacturer name:

Vehicle Model:

Approval mark position: Outer lens

Manufacturer's name and address:

J.W. Speaker Corporation  
 N120 W19434 Freistadt Road  
 P.O. Box 1011  
 Germantown, WI 53022-8211 U.S.A.

If applicable, name and address of manufacturer's representative: Not Applicable

Manufacturing Plant(s) Address



J.W. Speaker Corporation  
N120 W19434 Freistadt Road  
P.O. Box 1011  
Germantown, WI 53022-8211 U.S.A.

Manufacturer/Applicant Contact Person Responsible for Agreement: Mike Herre

Test Location:

J.W. Speaker Corporation  
N120 W19434 Freistadt Road  
P.O. Box 1011  
Germantown, WI 53022-8211 U.S.A.

Description of lamp

Category: A

	Front	steady luminous intensity	variable luminous intensity
Position	A	R or R1	R2
Stop lamp	--	S1 or S3	S2 or S4
End outer marker	AM	RM1	RM2

Note: On devices which may be used as part of an assembly of two lamps, the additional letter "D" to the right of the symbol mentioned above.

On interdependent lamps, which may be used as part of an interdependent lamp system, the additional letter "Y" to the right of the symbol mentioned above.

For mounting

- a. outside vehicle or
- b. inside vehicle
- c. or both

Colour of light emitted

Front position	White
Rear position	<red>
Stop lamp	<red>
End outer marker	<white or red>

Variable luminous intensity No

Kind of light source(s) LED

Number of light source(s) 2

If multiple LED light sources are used, give a brief technical description of a failed LED  
One LED out all LEDs are out.

Rated voltage and the rated wattage: 12-24 VDC, 2.0 W Max

Function(s) produced by an interdependent lamp forming part of an interdependent lamp system:

Front position lamp	No
R1 Rear position lamp	No
R2 Rear position lamp	No
S1 Stop lamp	No
S2 Stop lamp	No
S3 Stop lamp	No
S4 Stop lamp	No
End-outline marker lamp	No

A brief technical description stating, in particular, with the exception of lamps with non-replaceable light source(s):

- (a) the category or categories of filament lamp(s) prescribed; this filament lamp category shall be one of those contained in Regulation No. 37
- (b) The light source module specific identification code. 3454320 (Model 8700 EVO2-S), PCB 3454640 (Model 8700 EVOJ-2)
- (c) In the case of a lamp with variable luminous intensity, a concise description of the variable intensity control, an arrangement diagram and a specification of the characteristics of the system ensuring the two levels of intensity

#### Geometrical Conditions

Only for installation on M<sub>1</sub> and/or N<sub>1</sub> category vehicles: No

Only for limited mounting height of equal to or less than 750 mm above the ground: No

The device may be installed on the vehicle with different inclinations of the reference axis in respect to the vehicle reference planes and to the ground or rotate around its reference axis.

Indicate the different conditions of installation (or different positions): No

#### Electronic Light Source Gear

Application of an electronic light source control gear/variable intensity control:

- (a) being part of the lamp: Yes
- (b) being not part of the lamp: No

Input voltage(s) supplied by an electronic light source control gear/variable intensity control:  
NA



Electronic light source control gear/variable intensity control manufacturer and identification number (when the light source control gear is part of the lamp but is not included into the lamp body): NA

#### Lamp material List

Optic Holder Material: Polycarbonate

Housing Material: Aluminum

Outer Lens: Material: Clear polycarbonate with RedSpot UVT-200 Hardcoating and  
FSI AF-6114 Anti-Fog coating

Solid Optical Lens Materials: Clear polycarbonate (D-lenses)

Clear PMMA (high beam Asphere)

Glass ( Low beam Asphere)

The materials making up the lenses and coatings, if any, shall be accompanied by the test report of the characteristics of these materials and coatings if they have already been tested.

Attach drawing(s) in sufficient detail to permit identification of the type of device and showing in what geometrical positions(s) the device may be mounted on the vehicle. The axis of observation to be taken as the axis of reference in the tests (horizontal angle  $H =$ , vertical angle  $V =$ ) and the point to be taken as the centre of reference in the said tests; the drawing shall show the position intended for the approval mark and eventually the additional symbols in relation to the circle of the approval mark.

**APPROVAL OF DAYTIME RUNNING LAMPS FOR POWER-DRIVEN  
 VEHICLES PURSUANT TO REGULATION NO 87.00**

Approval Number Issued: 6796

Extension No.: 01

CHANGES FROM THE ORIGINAL CERTIFICATION			
Date	Rev	Author's Initials	Changes
8/15/16	0	MJH	Initial Approval
2/1/17	01	MJH	Added Model 8700 EVOJ2, part number 0553980 and 0554550

Group Approval: Yes

If group approval, list Regulations included in the group approval: Reg. 112, Reg. 7, Reg. 87

Trade name or mark of the device: Speaker

Manufacturer's name for the type of device: 8700 EVO2-S, 8700 EVOJ2

Component(s) to be covered by approval: 0552760, 0553320, 0553980, 0554550

Approval mark position: Outer Lens

Manufacturer's name and address:

J.W. Speaker Corporation  
 N120 W19434 Freistadt Road  
 P.O. Box 1011  
 Germantown, WI 53022-8211 U.S.A.

If applicable, name and address of manufacturer's representative:

J.W. Speaker Corporation  
 N120 W19434 Freistadt Road  
 P.O. Box 1011

Application for Approval to Regulation 87  
 Revision Date: July 2012



Germantown, WI 53022-8211 U.S.A.

Manufacturing Plant(s) Address

J.W. Speaker Corporation  
N120 W19434 Freistadt Road  
P.O. Box 1011  
Germantown, WI 53022-8211 U.S.A.

Manufacturer/Applicant Contact Person Responsible for Agreement: Mike Herre

Test Location:

J.W. Speaker Corporation  
N120 W19434 Freistadt Road  
P.O. Box 1011  
Germantown, WI 53022-8211 U.S.A.

Description of lamp

Category of light source(s): not applicable

Number of light source(s): 2

Kind of light source(s): LED

Rated voltage and the rated wattage: 12-24 VDC, 19 W max

Electronic Light Source Gear

Application of an electronic light source control gear/variable intensity control:

- (a) being part of the lamp: Yes
- (b) being not part of the lamp: not applicable

Input voltage(s) supplied by an electronic light source control gear/variable intensity control:  
not applicable

Electronic light source control gear/variable intensity control manufacturer and identification number (when the light source control gear is part of the lamp but is not included into the lamp body): not applicable

Lamp material List

Optic Holder Material: Polycarbonate



Housing Material: Aluminum

Outer Lens: Material: Clear polycarbonate with RedSpot UVT-200 Hardcoating and  
FSI AF-6114 Anti-Fog coating

Solid Optical Lens Materials: clear polycarbonate (D-lenses)

Clear PMMA (high beam Asphere)

Glass ( Low beam Asphere)

The materials making up the lenses and coatings, if any, shall be accompanied by the test report of the characteristics of these materials and coatings if they have already been tested.

Attach drawing(s) in sufficient detail to permit identification of the type of device and showing in what geometrical positions(s) the device may be mounted on the vehicle. The axis of observation to be taken as the axis of reference in the tests (horizontal angle  $H =$ , vertical angle  $V =$ ) and the point to be taken as the centre of reference in the said tests; the drawing shall show the position intended for the approval mark and eventually the additional symbols in relation to the circle of the approval mark.

## APPROVAL OF A TYPE OF HEADLAMP PURSUANT TO REGULATION NO 112

Approval Number Issued: 6796

Extension No. 01

CHANGES FROM THE ORIGINAL CERTIFICATION		
Date	Rev	Changes
8/15/16	0	Initial Approval
2/1/17	01	Added Model EVOJ2, part number 0553980 and 0554550

Group Approval: yes

If group approval, list Regulations included in the group approval: Reg. 7, Reg. 112, Reg. 87

Trade name or mark of the device: Speaker

Manufacturer's name for the type of device: 8700 EVO2-S, 8700 EVOJ2

Component(s) to be covered by approval: 0552760, 0553320, 0553980, 0554550

Manufacturer's name and address:

J.W. Speaker Corporation  
 N120 W19434 Freistadt Road  
 P.O. Box 1011  
 Germantown, WI 53022-8211 U.S.A.

If applicable, name and address of manufacturer's representative: Not Applicable

Manufacturing Plant(s) Address

J.W. Speaker Corporation  
 N120 W19434 Freistadt Road

Application For Approval To Regulation 112





P.O. Box 1011  
Germantown, WI 53022-8211 U.S.A.

Manufacturer/Applicant Contact Person Responsible for Agreement: Mike Herre

Test Location:

J.W. Speaker Corporation  
N120 W19434 Freistadt Road  
P.O. Box 1011  
Germantown, WI 53022-8211 U.S.A.

### Description of Headlamp

Suitability for right-hand or left-hand traffic or for both traffic systems: RHT

If suitable for both explain the means of the selective setting and how the design shall preclude inadvertent shifting from one setting to the other or setting in an intermediate position: NA

The kind of beam produced (passing beam, driving beam or both): Both

Headlamp is equipped with an adjustable reflector: No

The height and mounting position(s) of the headlamp in relation to the ground: NA

A brief technical description including, in the case where headlamps are used to produce bend lighting:

Category as described by the relevant marking:

C	C →	C ↔	R	R PL	CR	CR →	CR ↔	C/R	C/R →
C/R ↔	C/ →	C/ ↔	C/ ↔	C PL →	C PL ↔	CPL ↔	CR PL →	CR PL ↔	CR PL ↔
C/R PL →	C/R PL ↔	C/R PL ↔	C/PL →	C/PL ↔	C/PL ↔	HC →	HC ↔	HC ↔	HR
HR PL →	HCR ↔	HCR ↔	HCR ↔	HC/R →	HC/R ↔	HC/R ↔	HC/ →	HC/ ↔	HC/ ↔
HC PL →	HC PL ↔	HC PL ↔	<b>HCR PL</b>		HCR PL →		HCR PL ↔		
HC/R PL →		HC/R PL ↔		HC/R PL ↔		HC/PL →		HC/PL ↔	

Class of headlamp: B

Rated voltage and wattage: 12-24 VDC

Driving Beam: 45W Max

Passing Beam: 24 W Max

Number and category(s) of filament lamp(s) as listed in Regulation No. 37 and its series of amendments:

Passing: NA

Driving: NA

Number and specific identification code(s) of LED module(s)

Passing: three 3-die LED array

Driving: four 3-die LED array, two 2 die LED array

A brief technical specification of the LED module(s) (include failure modes): NA (

The light source module specific identification code: NA (Non-replaceable LED module)

Number and specific identification code(s) of electronic light source control gear(s):

PCB 3454320 (Model 8700 EVO2-S), PCB 3454640 (Model 8700 EVOJ-2)

For electronic light source control gear, information on the electrical interface necessary for approval testing:

Manufacturer's declared maximum luminous intensity: 17.5

Headlamp material List

Optic Holder Material: Polycarbonate

Housing Material: Aluminum

Outer Lens: Material: Clear polycarbonate with RedSpot UVT-200 Hardcoating and

FSI AF-6114 Anti-Fog coating

Solid Optical Lens Materials: clear polycarbonate (D-lenses)

Clear PMMA (high beam Asphere)

Glass ( Low beam Asphere)

The materials making up the lenses and coatings, if any, shall be accompanied by the test report of the characteristics of these materials and coatings if they have already been tested.

Approval mark position: Outer lens

Attach drawings in sufficient detail to permit identification of the type and representing a frontal view of the headlamp, with details of lens ribbing if any, and the cross-section. The drawings shall indicate the space(s) reserved for the approval mark and in case of LED module(s) also the space reserved for the specific identification code(s) of the module(s). If the headlamp is equipped with an adjustable reflector, an indication of the mounting position(s) of the headlamp in relation to the ground and the longitudinal median plane of the vehicle, if the headlamp is for use in that (those) position(s) only;



**RESTRICTED CONFIDENTIAL DOCUMENT**  
THIS DRAWING AND ALL INFORMATION SHOWN HEREON ARE THE EXCLUSIVE PROPERTY OF J.W. SPEAKER AND ARE SUBMITTED ONLY ON A CONFIDENTIAL BASIS. THE RECIPIENT AGREES NOT TO REPRODUCE THE DRAWING, TO RETURN IT UPON REQUEST, AND THAT NO DISCLOSURE OF THE DRAWING OR THE INFORMATION SHOWN HEREON WILL BE MADE TO A THIRD PARTY WITHOUT THE PRIOR WRITTEN CONSENT OF J.W. SPEAKER.

BOARD / GROMMET DESIGNATION	18GA WIRE	WIRE FUNCTION
0	BLACK	GROUND
1	YELLOW	LOW
2	WHITE	HIGH
3	RED	POSITION
4	BLUE	DRL

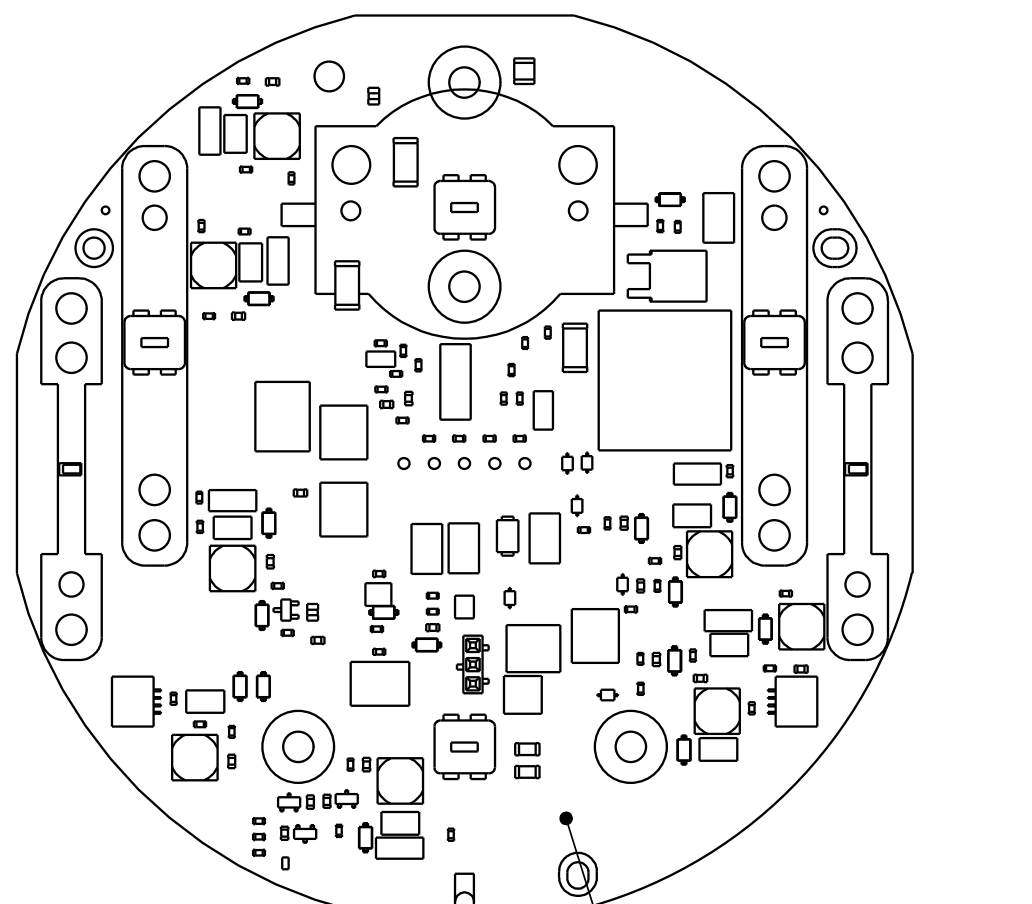
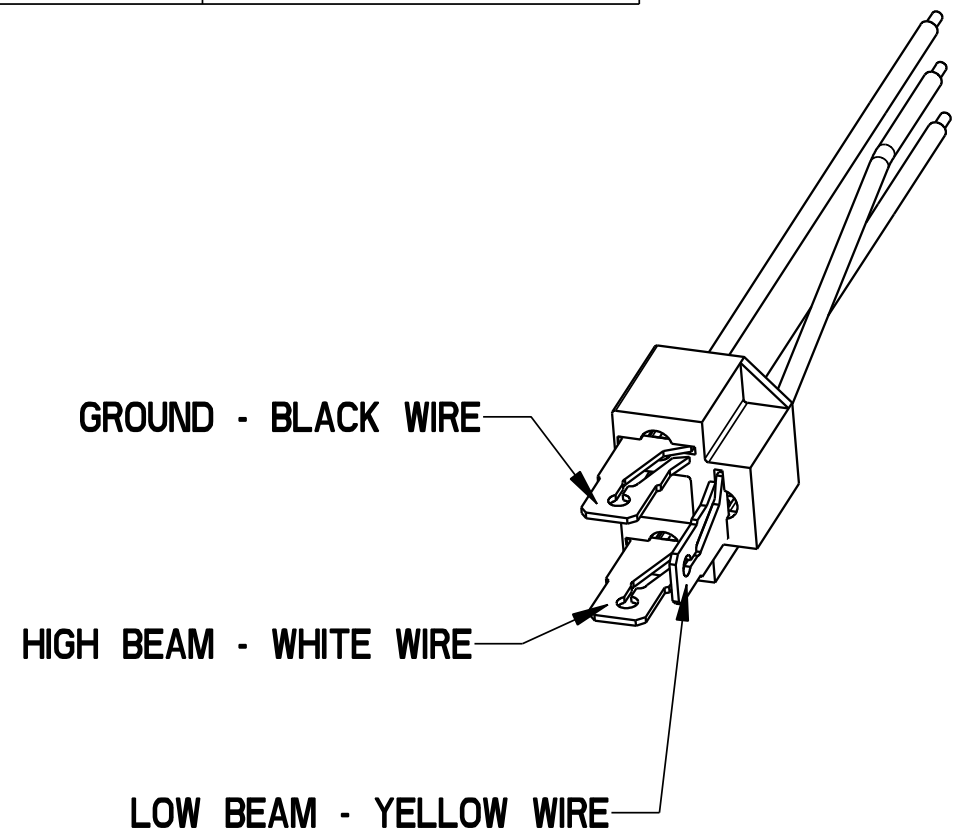
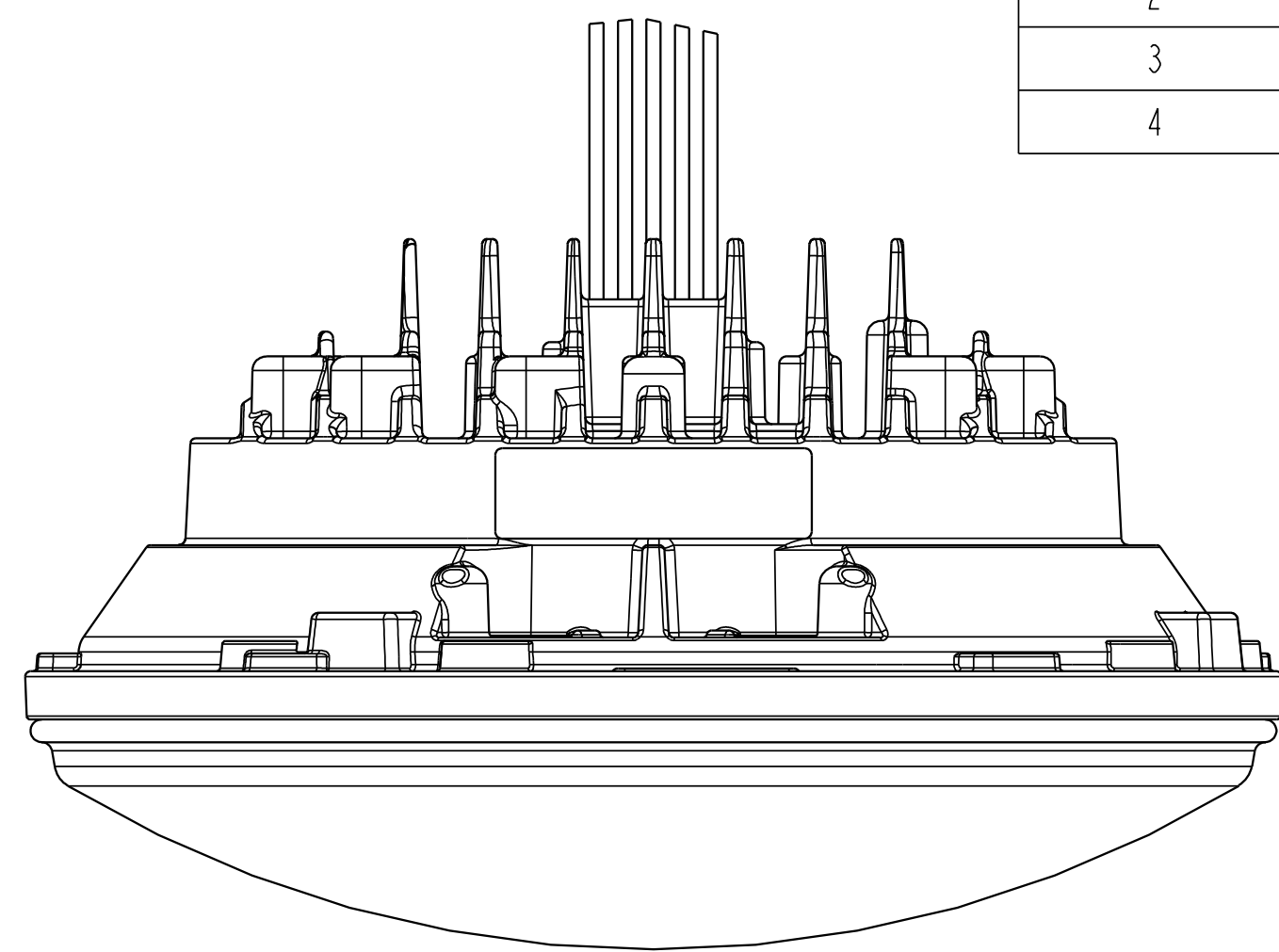

PCB ASSEMBLY  
P/N: 3454640

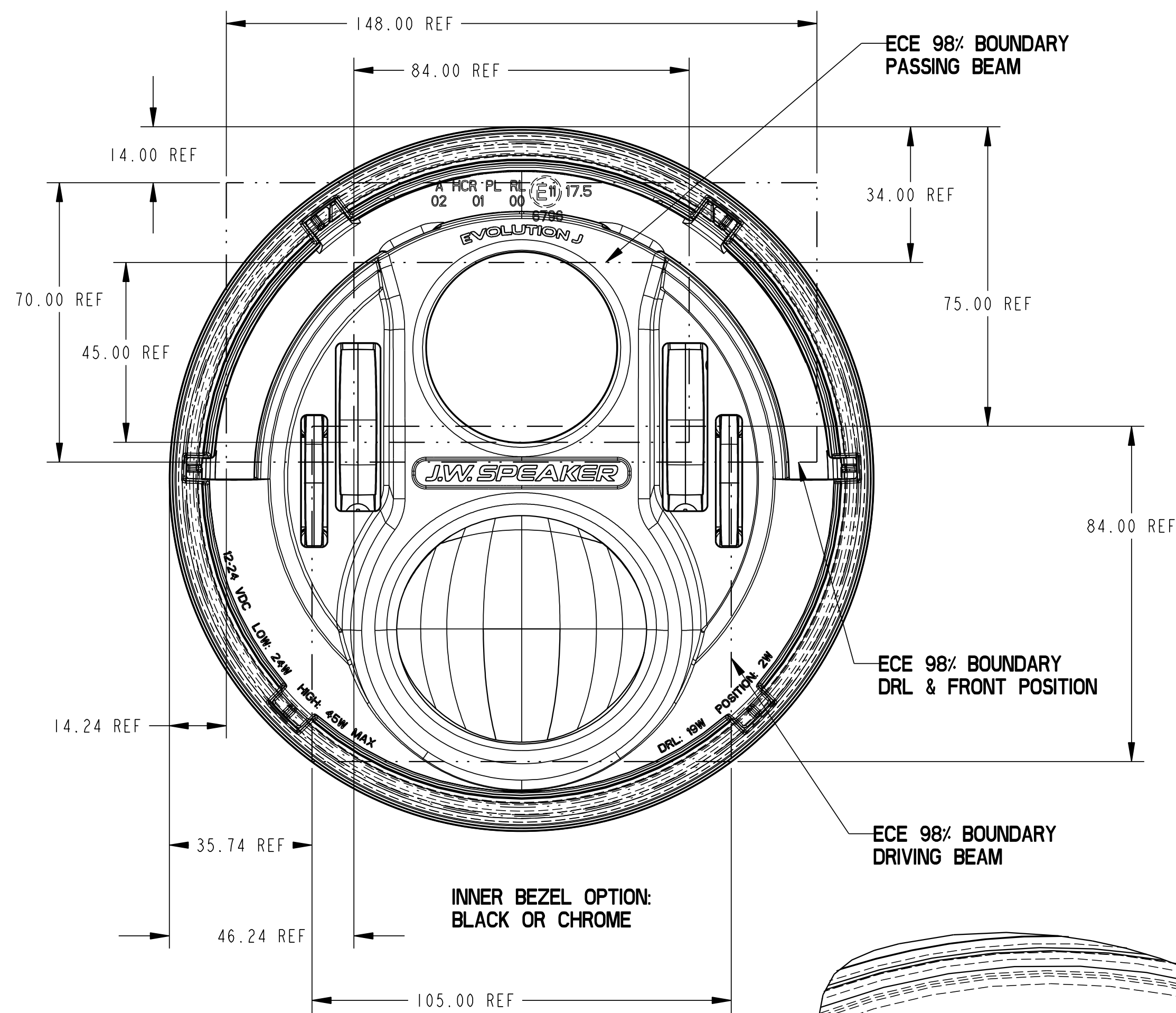
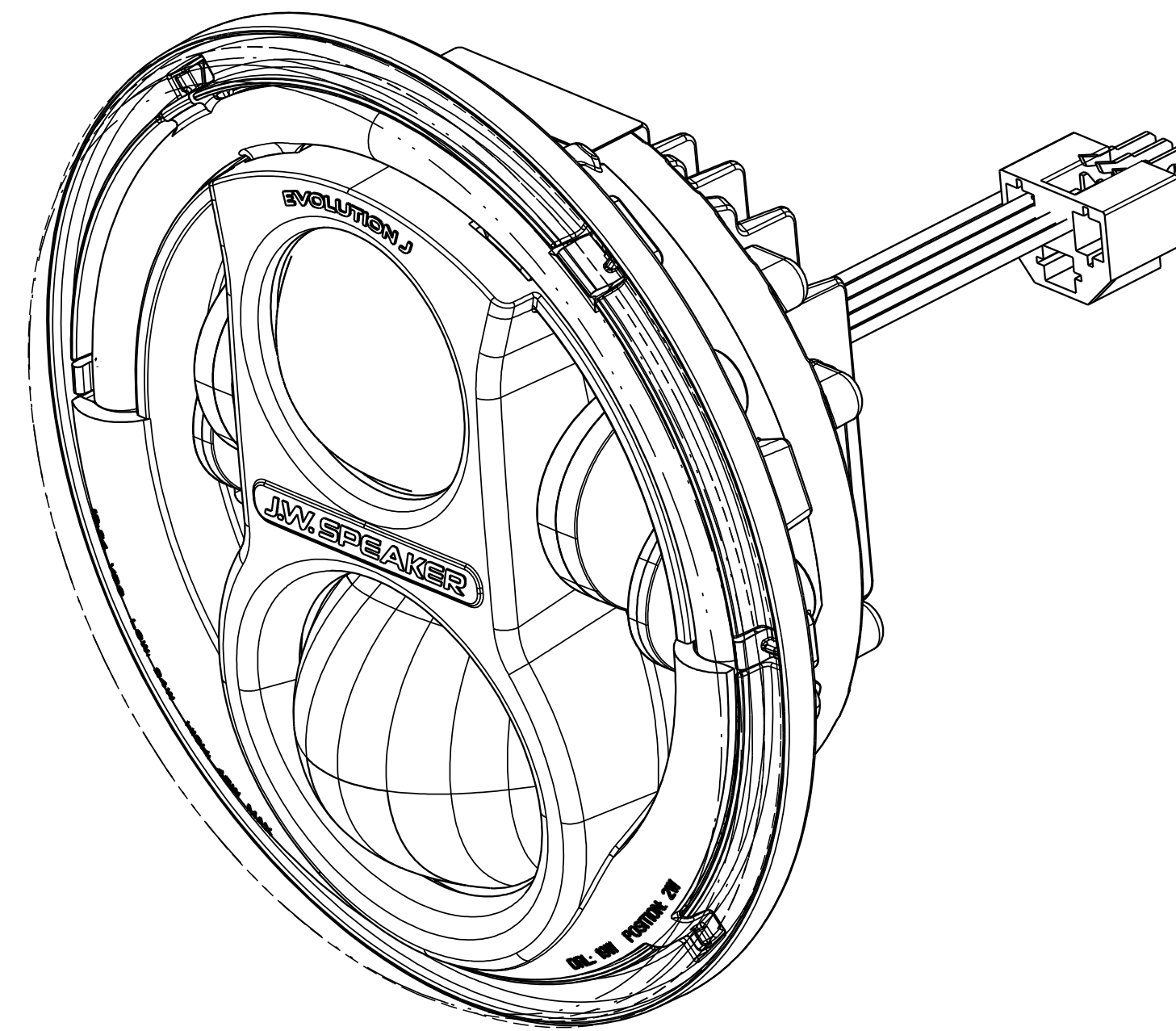

INNER BEZEL OPTION:  
BLACK OR CHROME

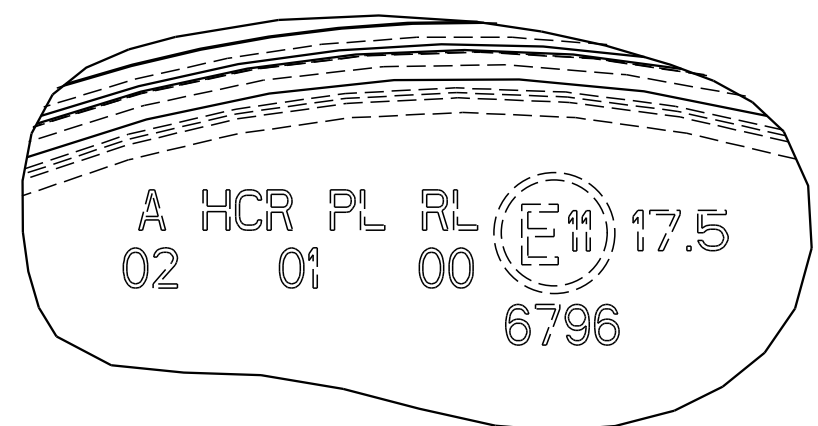

SCALE 2.000

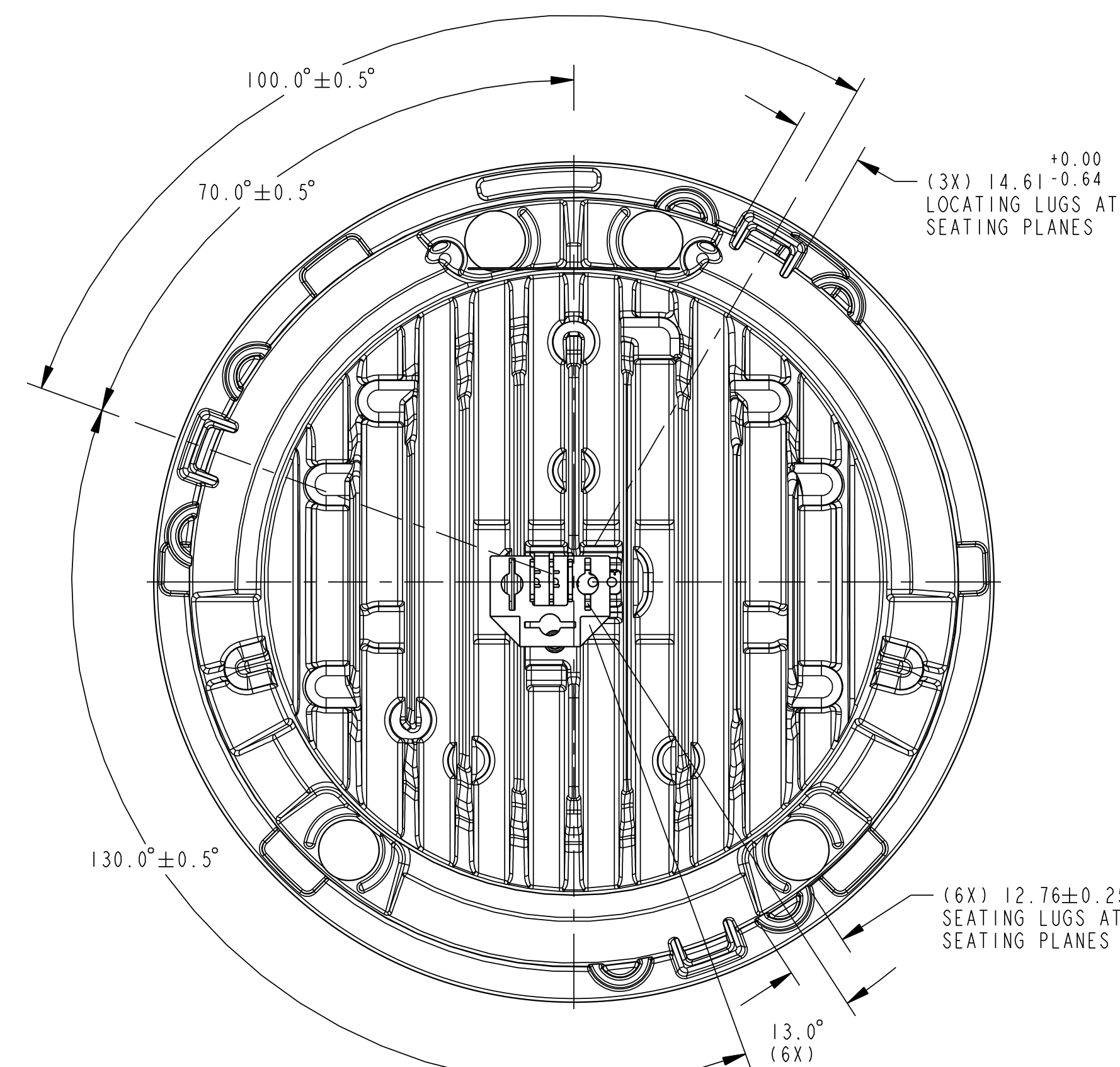
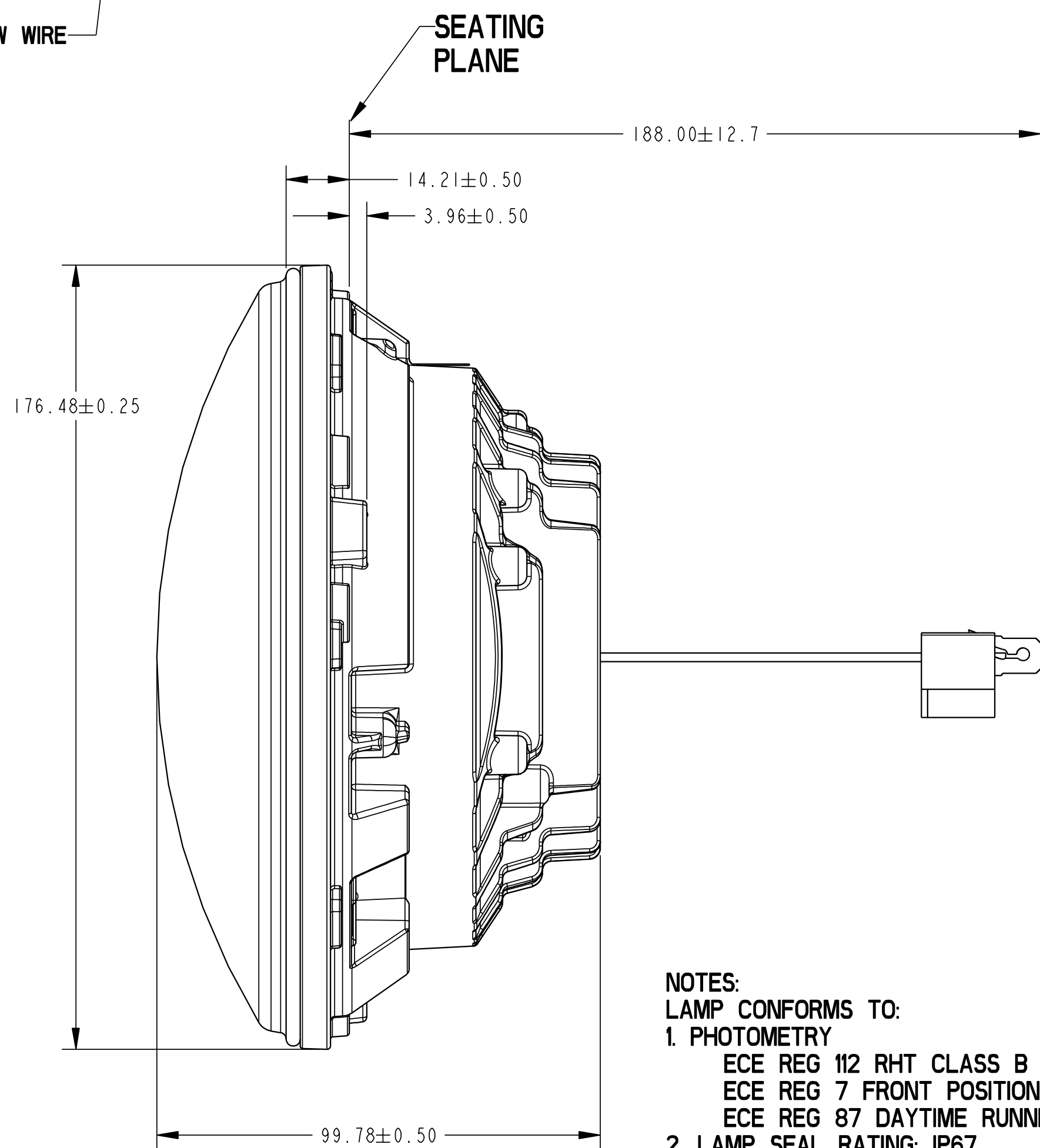

+0.00  
(3X) 14.61±0.64  
LOCATING LUGS AT  
SEATING PLANES

(6X) 12.76±0.25  
SEATING LUGS AT  
SEATING PLANES

- NOTES:  
LAMP CONFORMS TO:
- PHOTOMETRY  
ECE REG 112 RHT CLASS B  
ECE REG 7 FRONT POSITION  
ECE REG 87 DAYTIME RUNNING LIGHT
  - LAMP SEAL RATING: IP67
  - ELECTRICAL SPECIFICATIONS  
A. DESIGN VOLTAGE: 12 VDC  
B. CURRENT DRAW: LOW BEAM at 12v: 2.0A  
HIGH BEAM at 12v: 3.6A  
D R L at 12v: 16A  
POSITION at 12v: 0.16A
  - JWS PRODUCT STANDARD FOR ON ROAD VEHICLES
  - ADDITIONAL SPECIFICATIONS  
A. MATING CONNECTOR: AMP 172651-2

QTY. REQ.	ITEM NO.	PART NUMBER	DESCRIPTION
0554553	PART NUMBER		

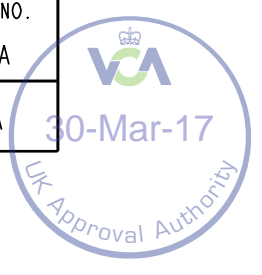



RESTRICTED CONFIDENTIAL DOCUMENT  
 THIS DRAWING AND ALL INFORMATION SHOWN HEREON ARE THE EXCLUSIVE PROPERTY OF J.W. SPEAKER AND ARE SUBMITTED ONLY ON A CONFIDENTIAL BASIS. THE RECIPIENT AGREES NOT TO REPRODUCE THE DRAWING, TO RETURN IT UPON REQUEST, AND THAT NO DISCLOSURE OF THE DRAWING OR THE INFORMATION SHOWN HEREON WILL BE MADE TO A THIRD PARTY WITHOUT THE PRIOR WRITTEN CONSENT OF J.W. SPEAKER.

BOARD / GROMMET DESIGNATION	18GA WIRE	WIRE FUNCTION
0	BLACK	GROUND
1	YELLOW	LOW
2	WHITE	HIGH
3	RED	POSITION
4	BLUE	DRL

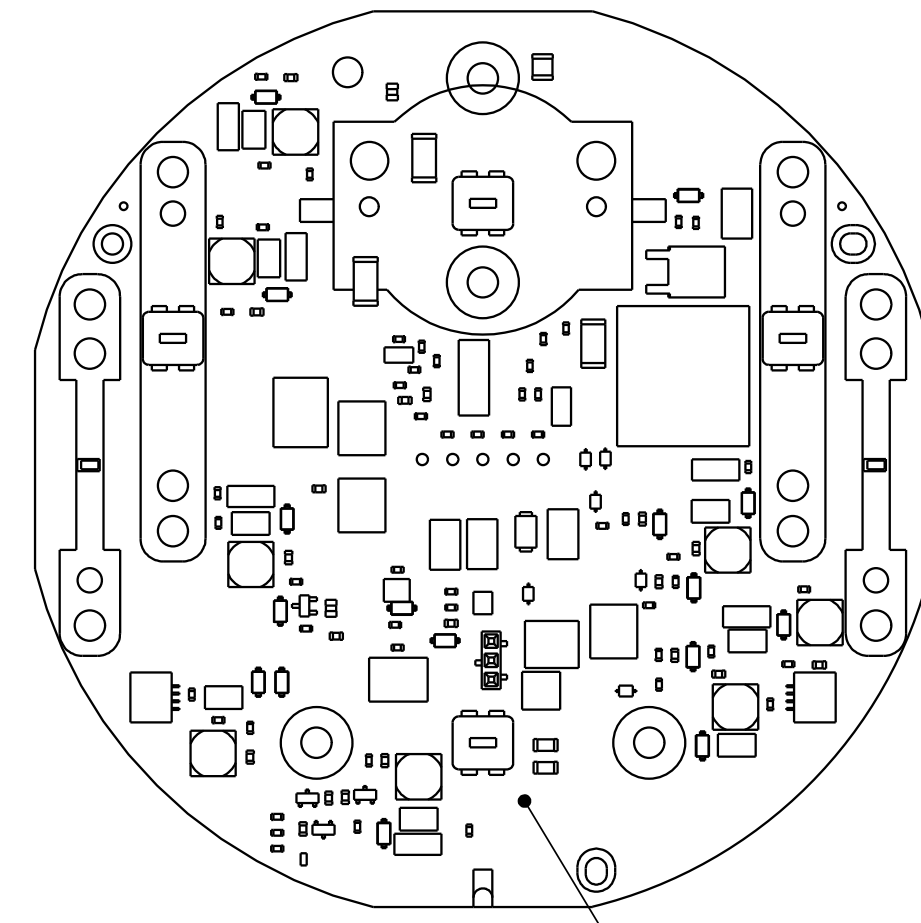
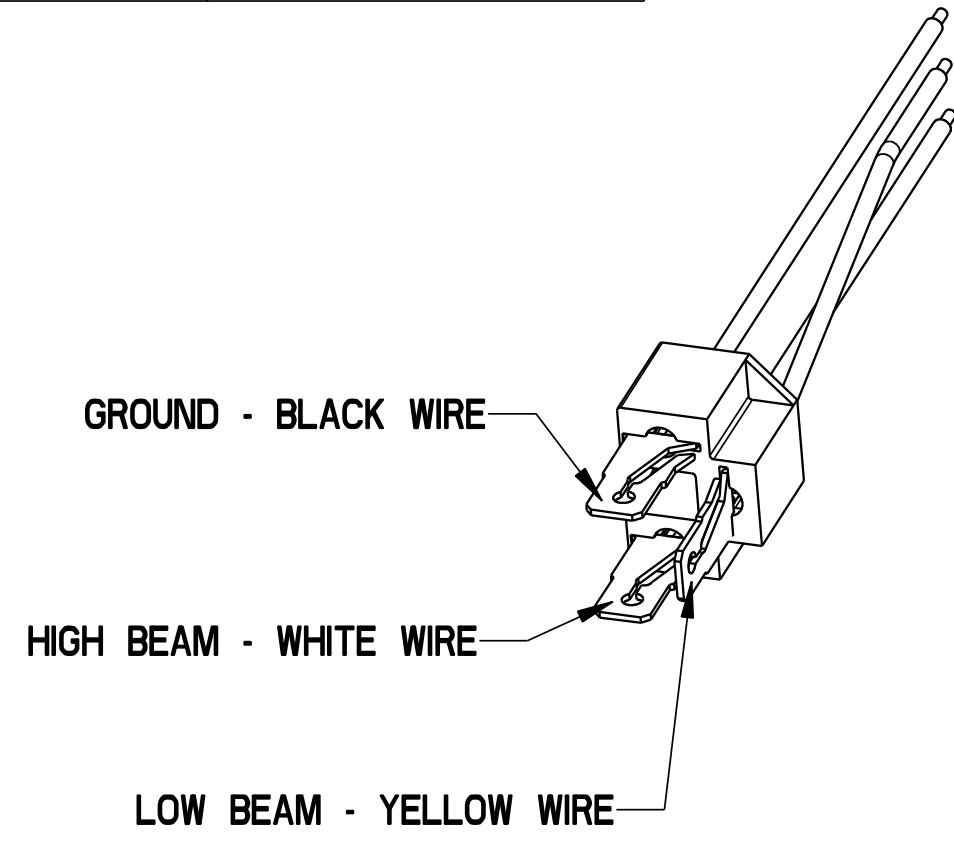
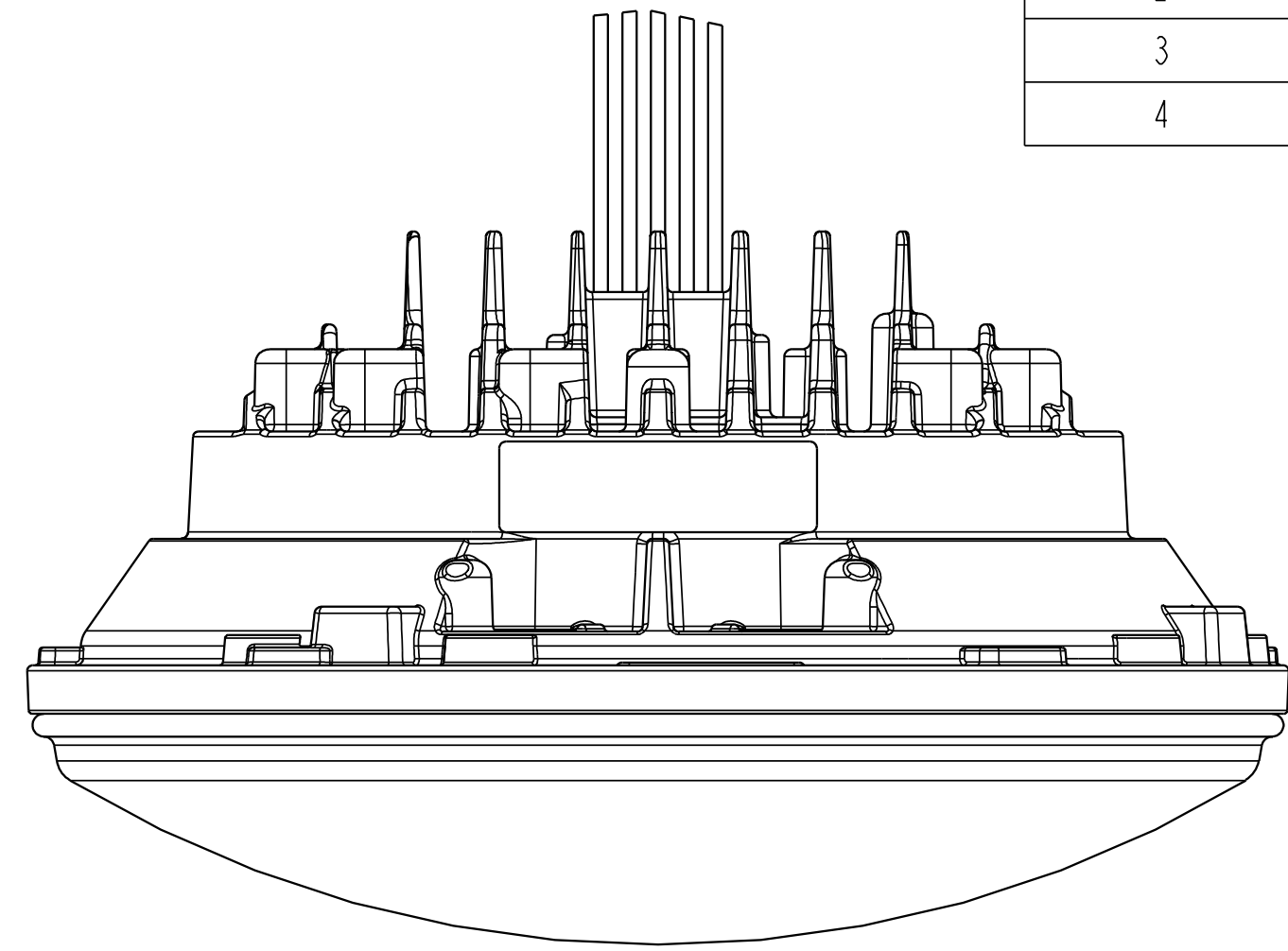

PCB ASSEMBLY  
 P/N: 3454640

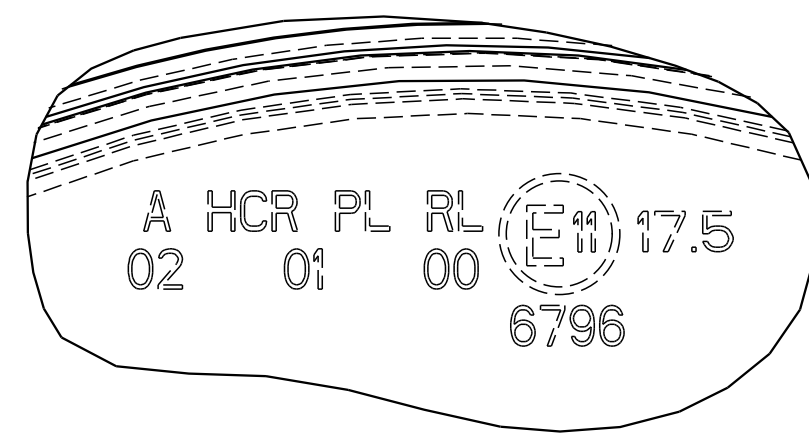
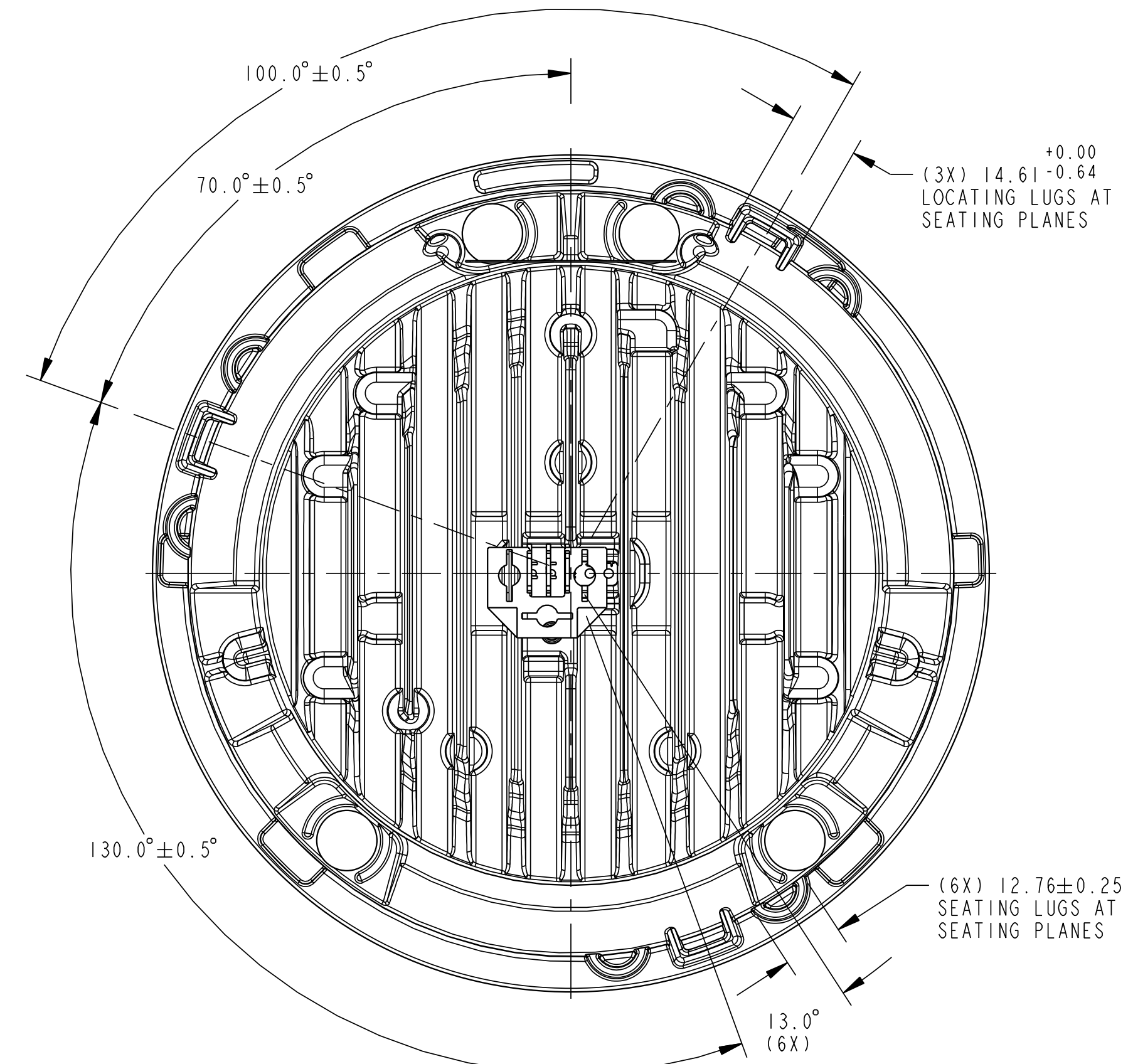
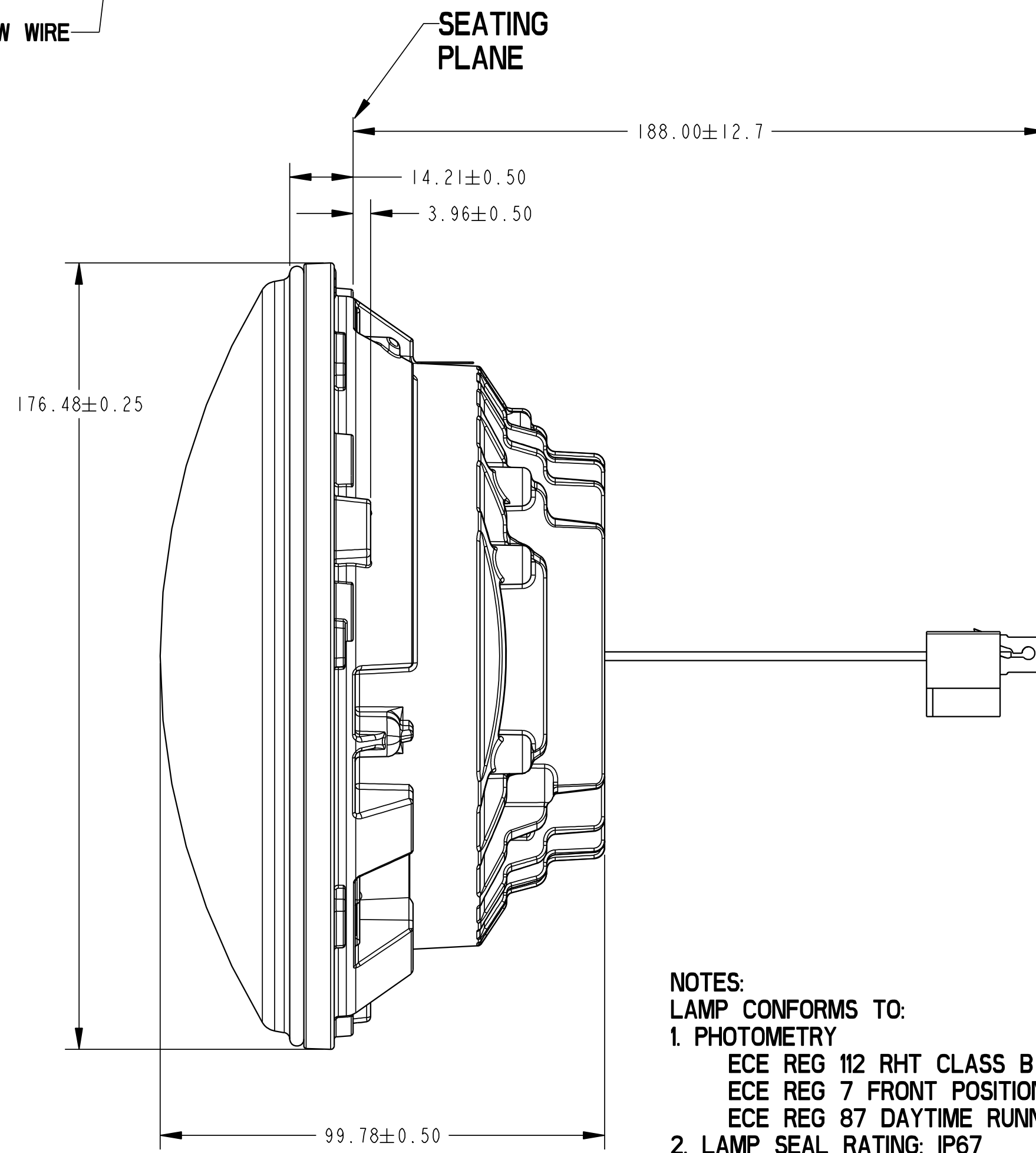
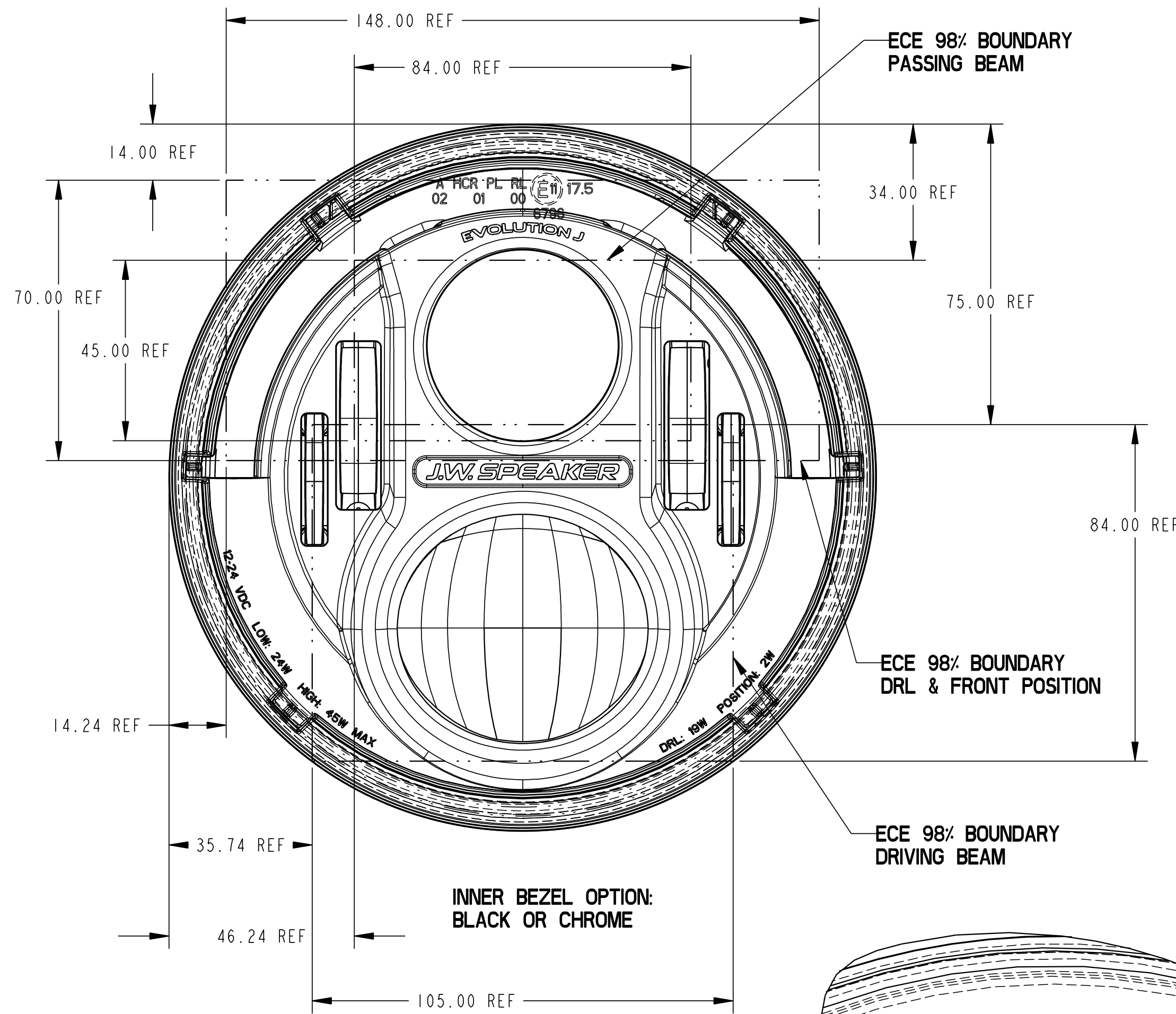
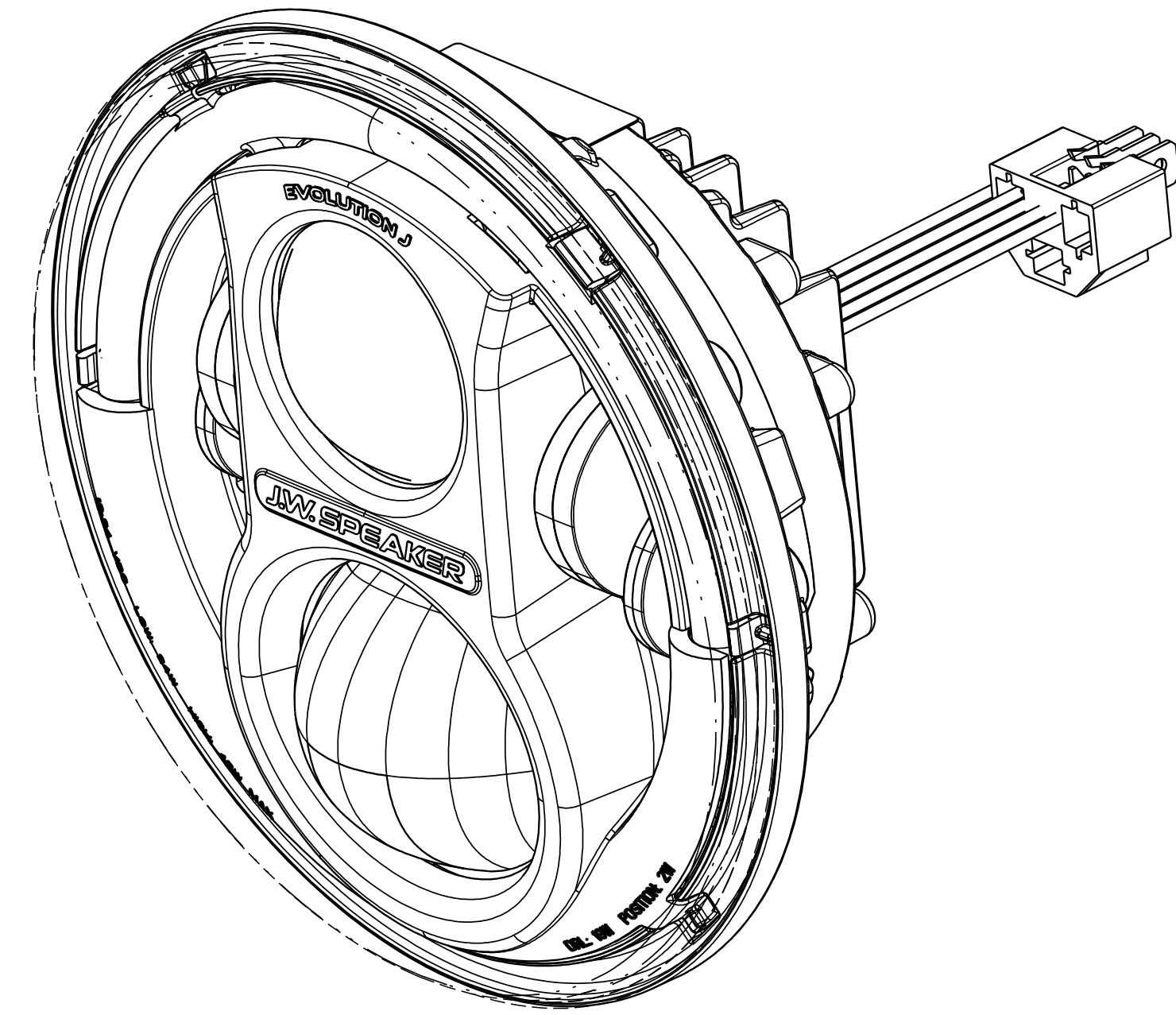

SCALE 2.000

- NOTES:  
 LAMP CONFORMS TO:  
 1. PHOTOMETRY  
 ECE REG 112 RHT CLASS B  
 ECE REG 7 FRONT POSITION  
 ECE REG 87 DAYTIME RUNNING LIGHT  
 2. LAMP SEAL RATING: IP67  
 3. ELECTRICAL SPECIFICATIONS  
 A. DESIGN VOLTAGE: 12 VDC  
 B. CURRENT DRAW: LOW BEAM at 12v: 2.0A  
 HIGH BEAM at 12v: 3.6A  
 D R L at 12v: 16A  
 POSITION at 12v: 0.16A  
 4. JWS PRODUCT STANDARD FOR ON ROAD VEHICLES  
 5. ADDITIONAL SPECIFICATIONS  
 A. MATING CONNECTOR: AMP 172651-2

QTY. REQ.	ITEM NO.	PART NUMBER	DESCRIPTION
0553983			
	PART NUMBER		
	UNLESS OTHERWISE SPECIFIED, ALL DIMENSIONS ARE IN MILLIMETERS	THIRD ANGLE PROJECTION	J.W. SPEAKER CORPORATION GERMANTOWN, WI
	DIMENSIONING AND TOLERANCING PER ASME Y14.5-2009 & ASME Y14.41-2003	SCALE: 1.000	MATERIAL: MANUFACTURED
		DATE: 02-Mar-17	TITLE: 8700-EVOJ2-12V ECE, RHT, SET
		DRAWN BY: M. MELZER	DWG. NO. D 0553980
			SHEET OF 2
			TOOL NO. N/A
			REV. A



RESTRICTED CONFIDENTIAL DOCUMENT  
 THIS DRAWING AND ALL INFORMATION SHOWN HEREON ARE THE EXCLUSIVE PROPERTY OF J.W. SPEAKER AND ARE SUBMITTED ONLY ON A CONFIDENTIAL BASIS. THE RECIPIENT AGREES NOT TO REPRODUCE THE DRAWING, TO RETURN IT UPON REQUEST, AND THAT NO DISCLOSURE OF THE DRAWING OR THE INFORMATION SHOWN HEREON WILL BE MADE TO A THIRD PARTY WITHOUT THE PRIOR WRITTEN CONSENT OF J.W. SPEAKER.

BOARD / GROMMET DESIGNATION	18GA WIRE	WIRE FUNCTION
0	BLACK	GROUND
1	YELLOW	LOW
2	WHITE	HIGH
3	RED	POSITION
4	BLUE	DRL

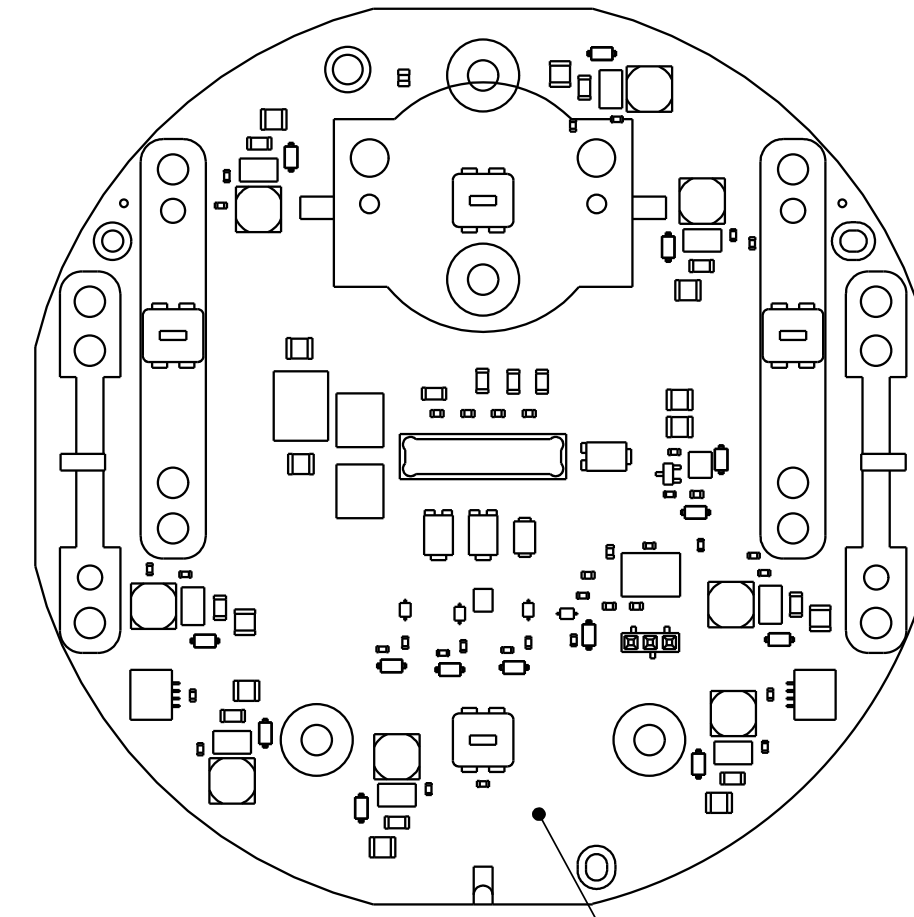

PCB ASSEMBLY  
 P/N: 3454320

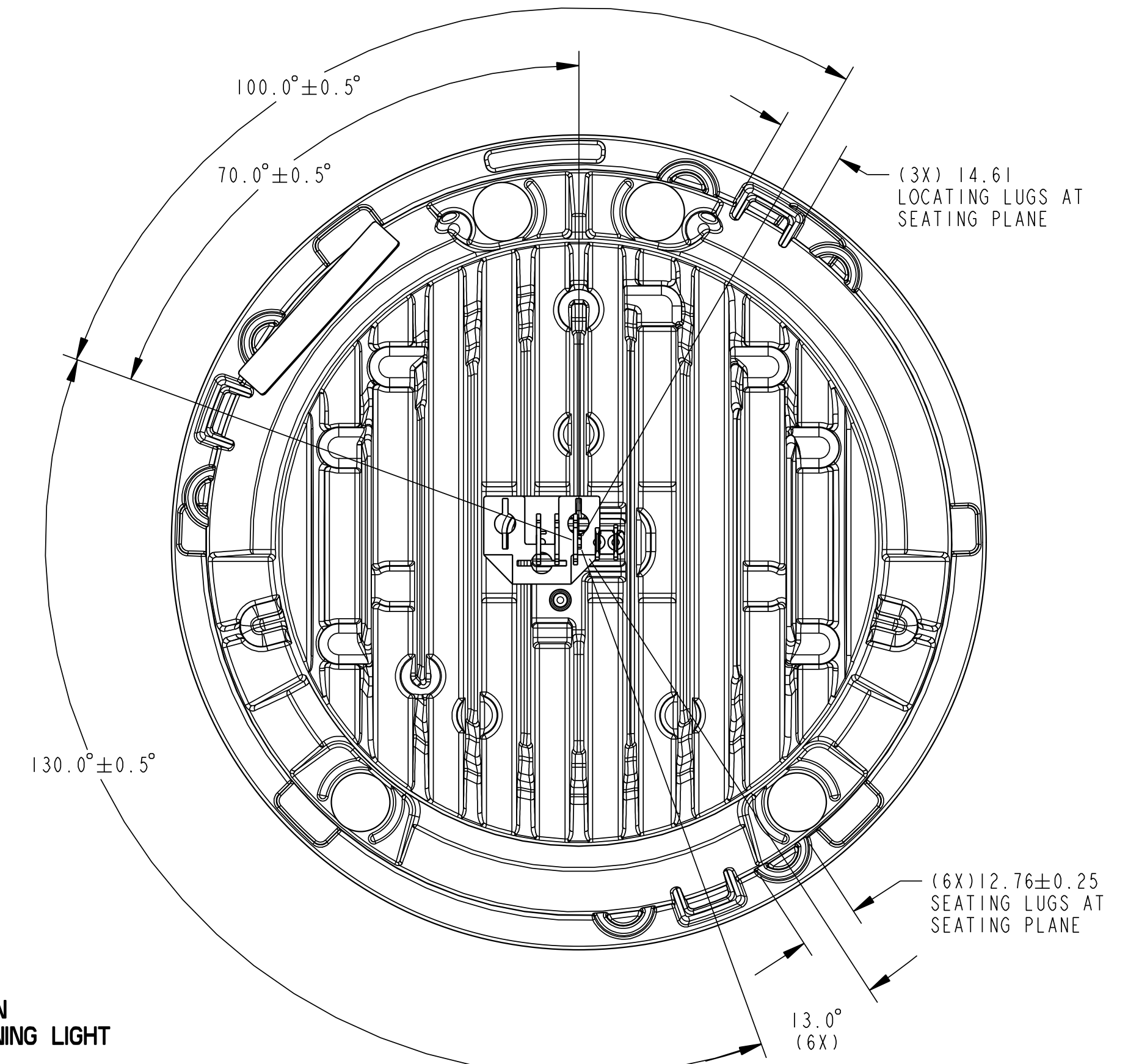
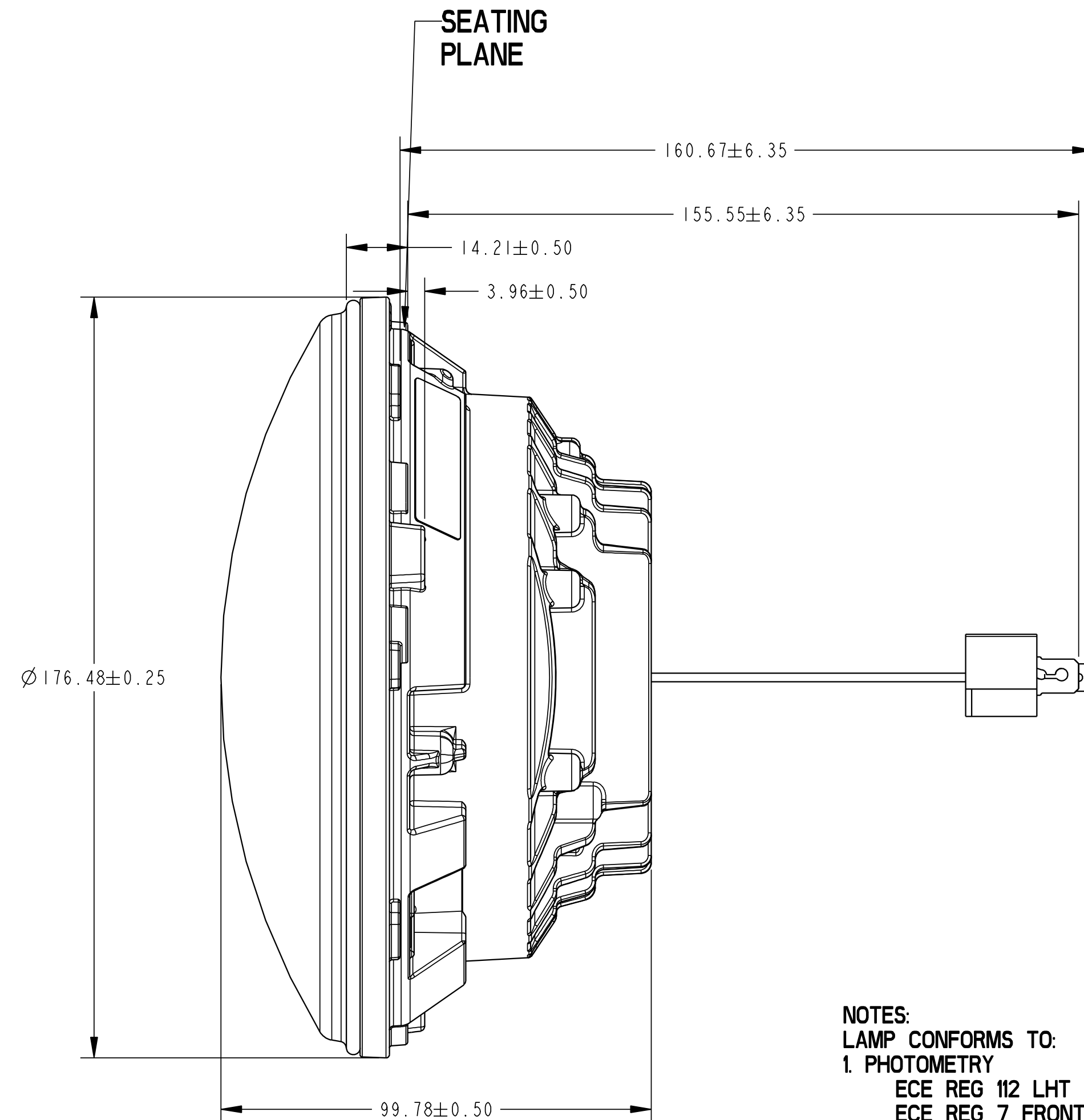
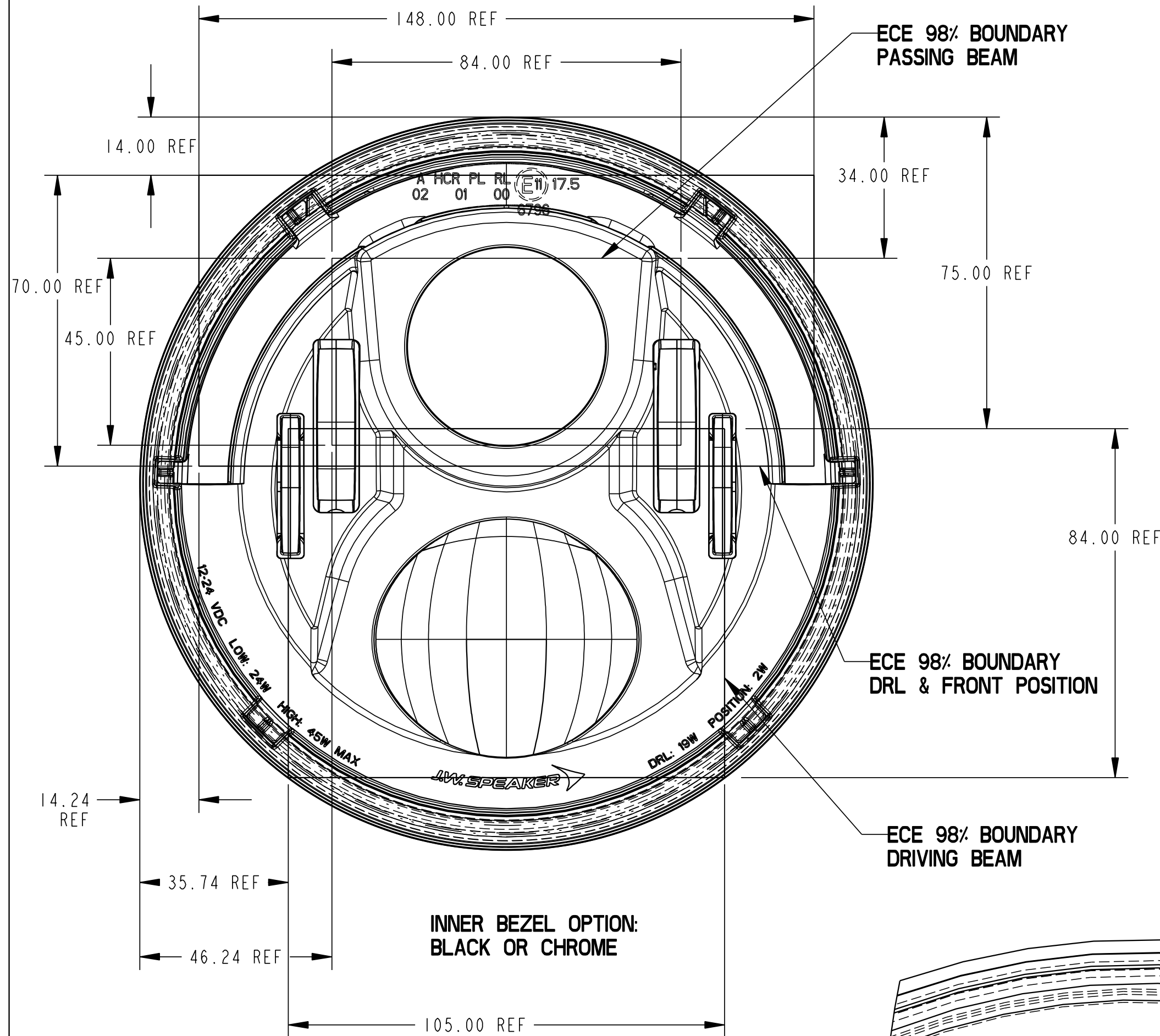
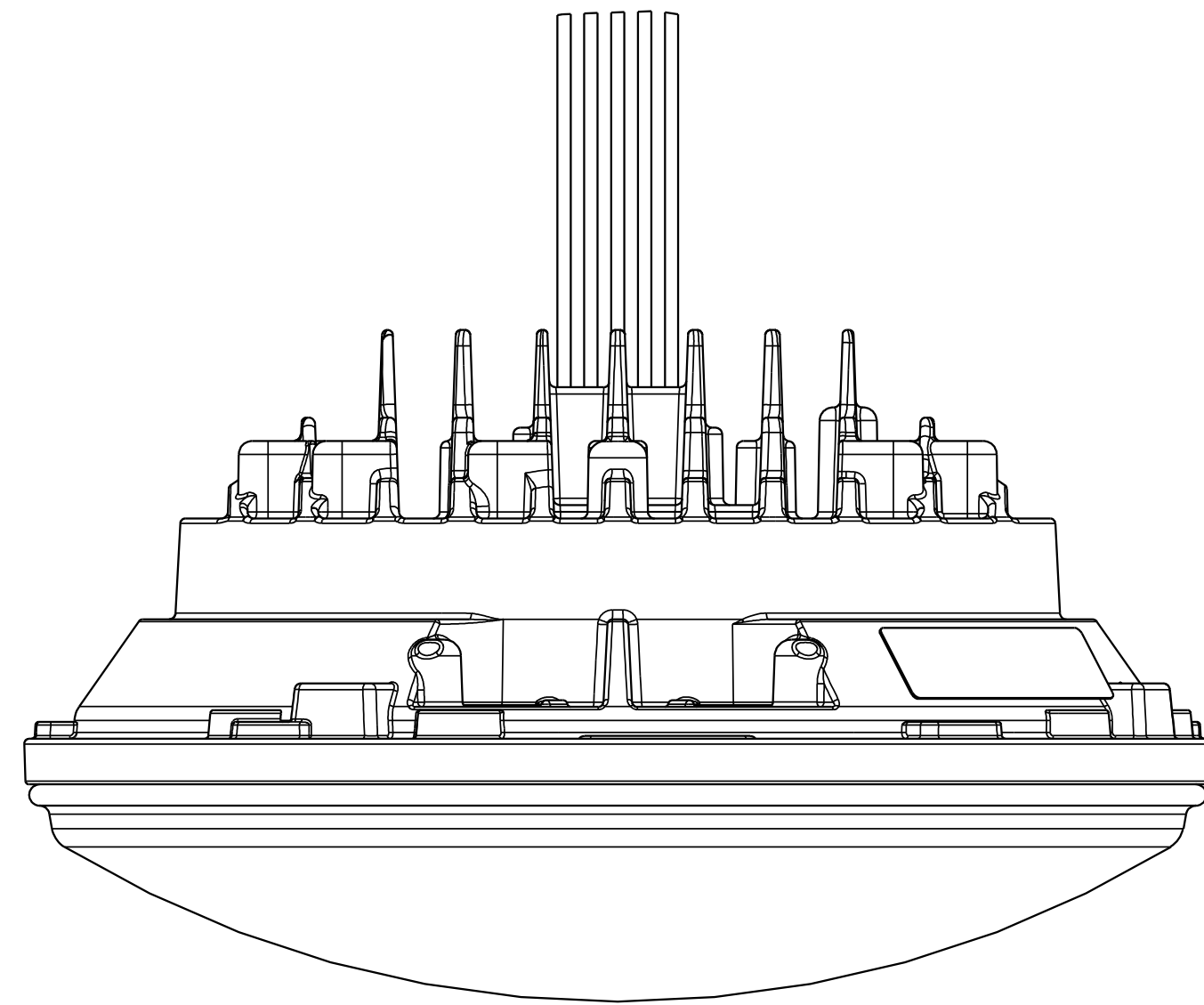
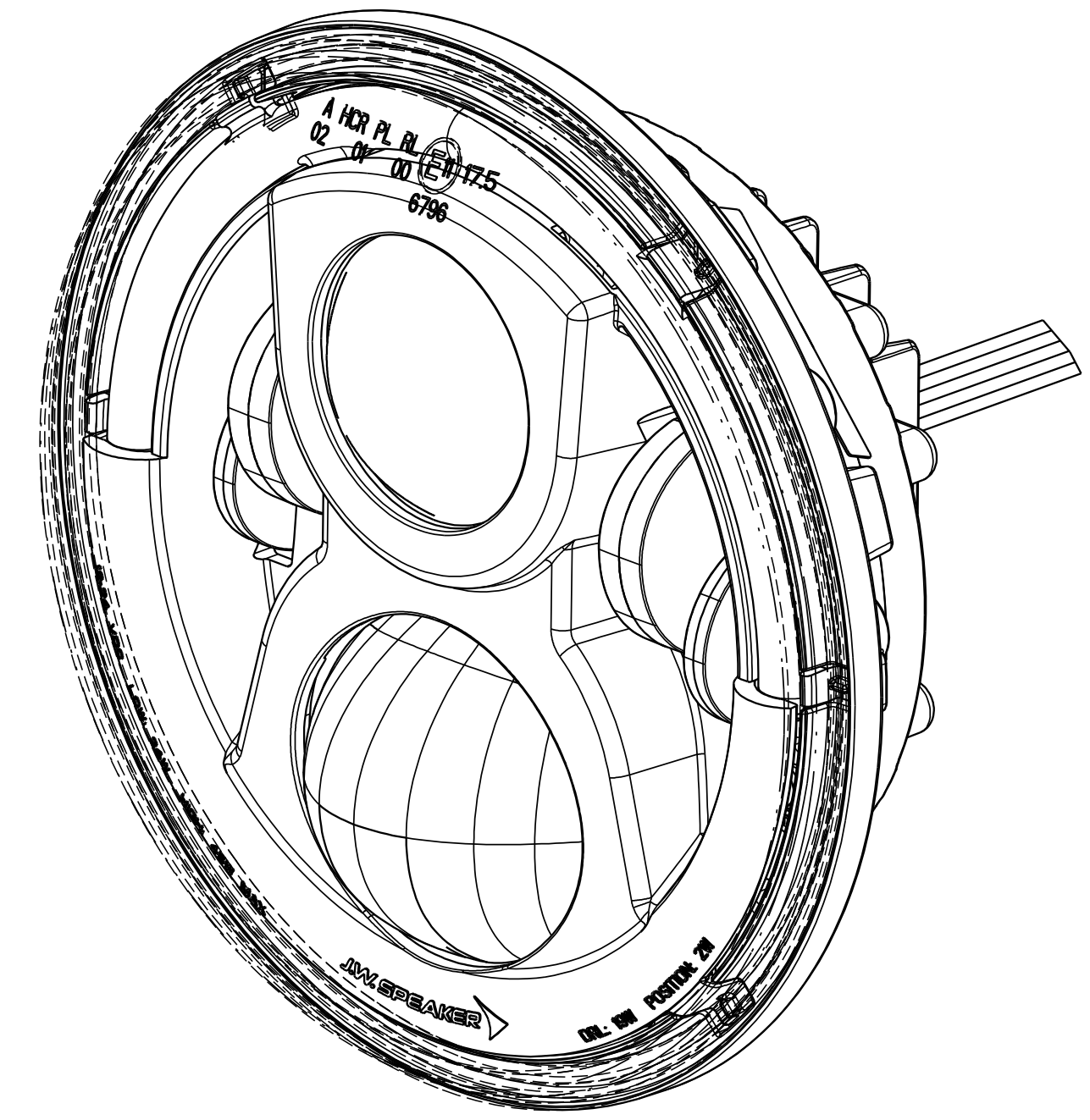

- NOTES:  
 LAMP CONFORMS TO:  
 1. PHOTOMETRY  
 ECE REG 112 LHT CLASS B  
 ECE REG 7 FRONT POSITION  
 ECE REG 87 DAYTIME RUNNING LIGHT  
 2. LAMP SEAL RATING: IP67  
 3. ELECTRICAL SPECIFICATIONS  
 A. DESIGN VOLTAGE: 12/24 VDC  
 B. CURRENT DRAW: LOW BEAM  $\phi$ 12v: 2.0A 24v: 1.1A  
 HIGH BEAM  $\phi$ 12v: 3.6A 24v: 1.8A  
 D R L  $\phi$ 12v: 1.6A 24v: 0.8A  
 POSITION  $\phi$ 12v: 0.16A 24v: 0.1A  
 4. JWS PRODUCT STANDARD FOR ON ROAD VEHICLES  
 5. ADDITIONAL SPECIFICATIONS  
 A. MATING CONNECTOR: AMP 172651-2  
 B. MATING CONNECTOR FOR POSITION:  
 AMP ULTRA-FAST 3-350819-2

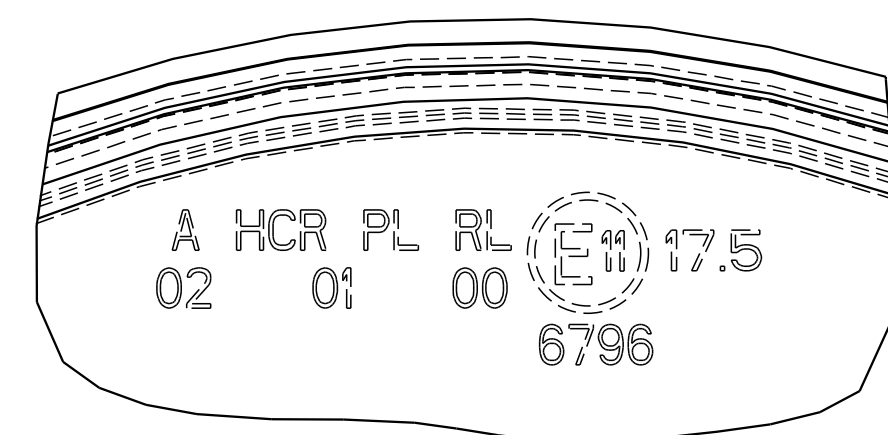

SCALE 2.000

ITEM NO.	0553321	8700 12/24V ECE EVO2-S, RHT, CHROME
ITEM NO.	0552761	8700 12/24V ECE EVO2-S, RHT, BLK
PART NUMBER	DESCRIPTION	
PART NUMBER	THIRD ANGLE PROJECTION	J.W. SPEAKER CORPORATION GERMANTOWN, WI
PART NUMBER	MATERIAL: MANUFACTURED	SHEET 1 OF 2
PART NUMBER	DATE: 21-Jul-16	TITLE: 8700 12/24V ECE EVO2-S, RHT, BLK
PART NUMBER	DWG. NO. D 0552760	TOOL NO. N/A
PART NUMBER	SCALE: 1.000	REV. A
PART NUMBER	DATE: 21-Jul-16	DATE: 21-Jul-16
PART NUMBER	DRAWN BY: M. HERRE	DRAWN BY: M. HERRE

