

REV  
G HDP24-24\* \* P/S \*

REVISIONS			
SYM	DESCRIPTION	DATE	APPROVED
D	REVISED PER E.O. P17590	1/17/02	R.D.R.
E	REVISED PER E.O. P17811	7/24/02	R.D.R.
F	REVISED PER E.O. P18119	4/14/03	R.D.R.
G	REVISED PER E.O. P18449	2-4-04	RDR

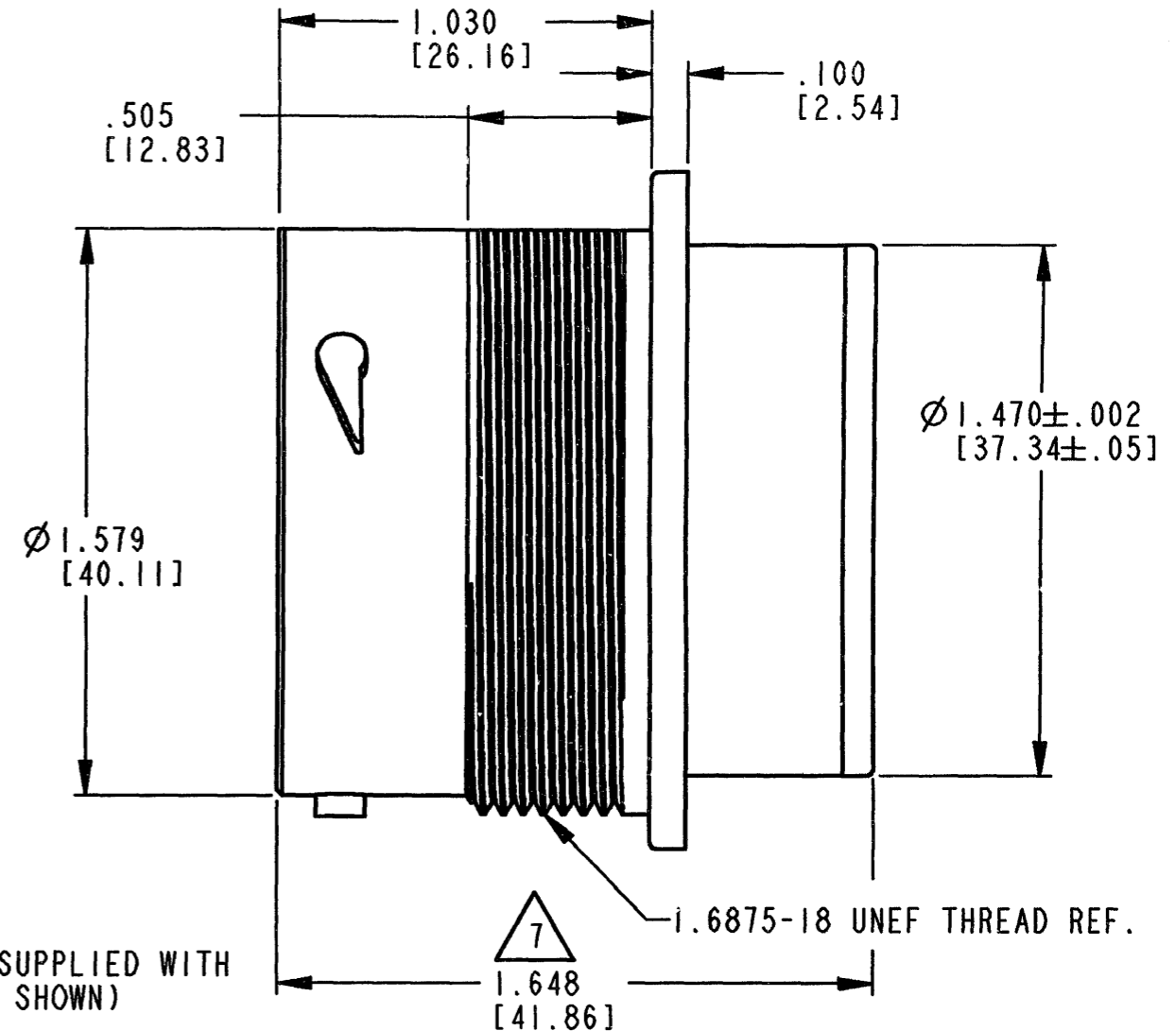
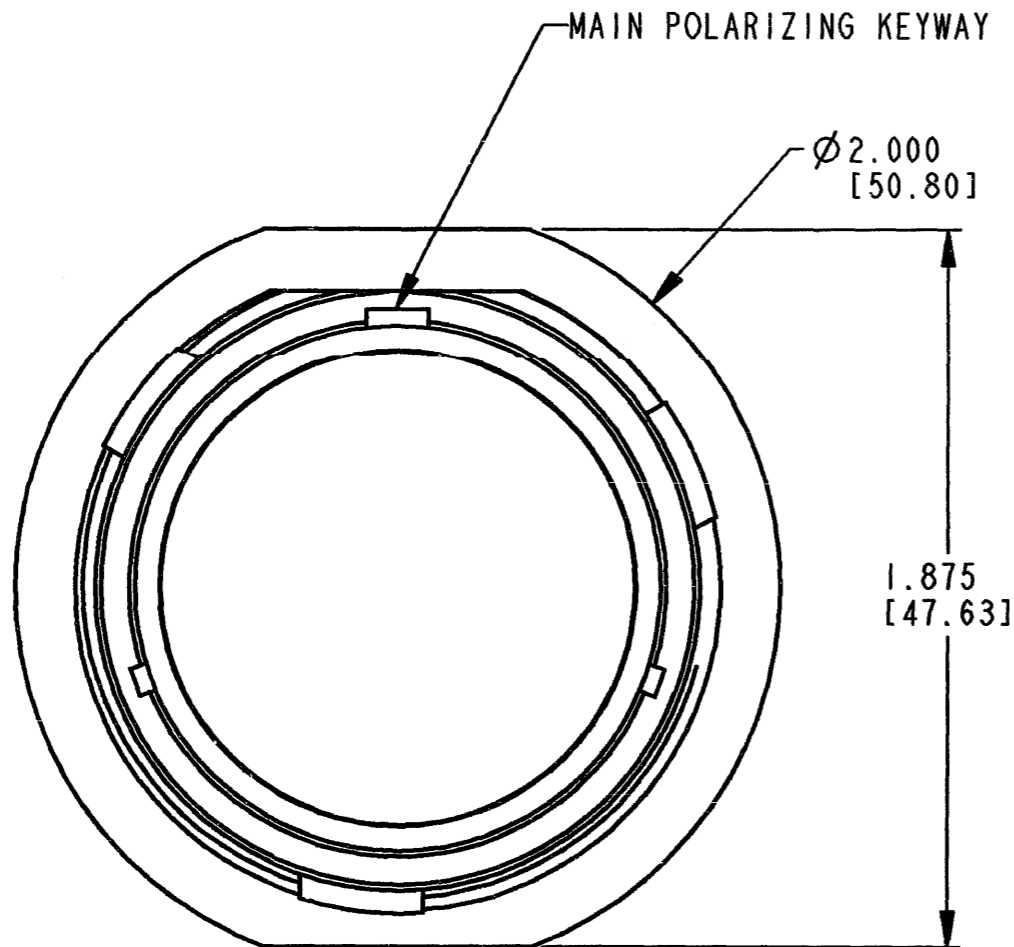

7. TOTAL DIMENSION WITH EXTENDED WIRE SEAL (WITH CONTACTS #4 OR #8 ONLY) IS 1.910 ± .025 [48.51 ± .63].

- 6. FOR ARRANGEMENT OF CONTACT LOCATION SEE ENVELOPE DRAWING 0425-014-2400.
- 5. FOR CONTACTS AND WIRES PERFORMANCE APPLICATION CHARACTERISTICS SEE ENVELOPE DRAWING 0425-015-0000.
- 4. FOR PERFORMANCE AND APPLICATION CHARACTERISTICS SEE ENVELOPE DRAWING 0425-021-0000.
- 3. DIMENSIONS ARE IN INCHES [MILLIMETERS].
- 2. RECOMMENDED PANEL THICKNESS: .062[1.58] TO .187[4.76].

- 10. RECEPTACLE IS SUPPLIED WITH DUST CAP. (NOT SHOWN)
- 9. DIMENSION TOLERANCES ARE ±.025 [±.63] UNLESS OTHERWISE NOTED.
- 8. THIS PART MATES WITH HDP26-24-\*\*\*S/P\*-\*\*\*\* (\*\*\*\*=ALL MODIFICATIONS) \* = TYPE OF SEAL.

NOTES: 1. THIS RECEPTACLE TO BE USED WITH 112263-90 (ALUMINUM) OR 2411-001-2405 (PLASTIC) PANEL NUT AND 2414-001-2486 LOCK WASHER.

SIGNATURE & DATE	
DR	S. BEARD 03MAR00
CHK	J. Lim 2/4/04
PE	R. Kalinski 1/15/04
APPD	S. Beard 1-16-04
SCALE	NONE WT _____

RECEPTACLE CONNECTOR  
SHELL SIZE 24  
BAYONET COUPLING  
HDP20 SERIES

ENVELOPE

CP	MATL. CODE
<b>The Deutsch Company</b> DEUTSCH I.P.D. 3850 INDUSTRIAL AVE. HEMET, CALIF. 92545	
<b>B</b>	<b>HDP24-24- * * P/S *</b>
DWG SIZE	CODE 11139 SHEET   OF