

REV B	HD34-24-XP/S*	REVISIONS			
		SYM	DESCRIPTION	DATE	APPROVED
		NC	NEW RELEASE PER E.O. P14915	12-4-95	R.D.R
		A	REVISED PER E.O. P15908	2-5-99	R.D.R.
B	REVISED PER E.O. P18134	5-23-03	RDR		

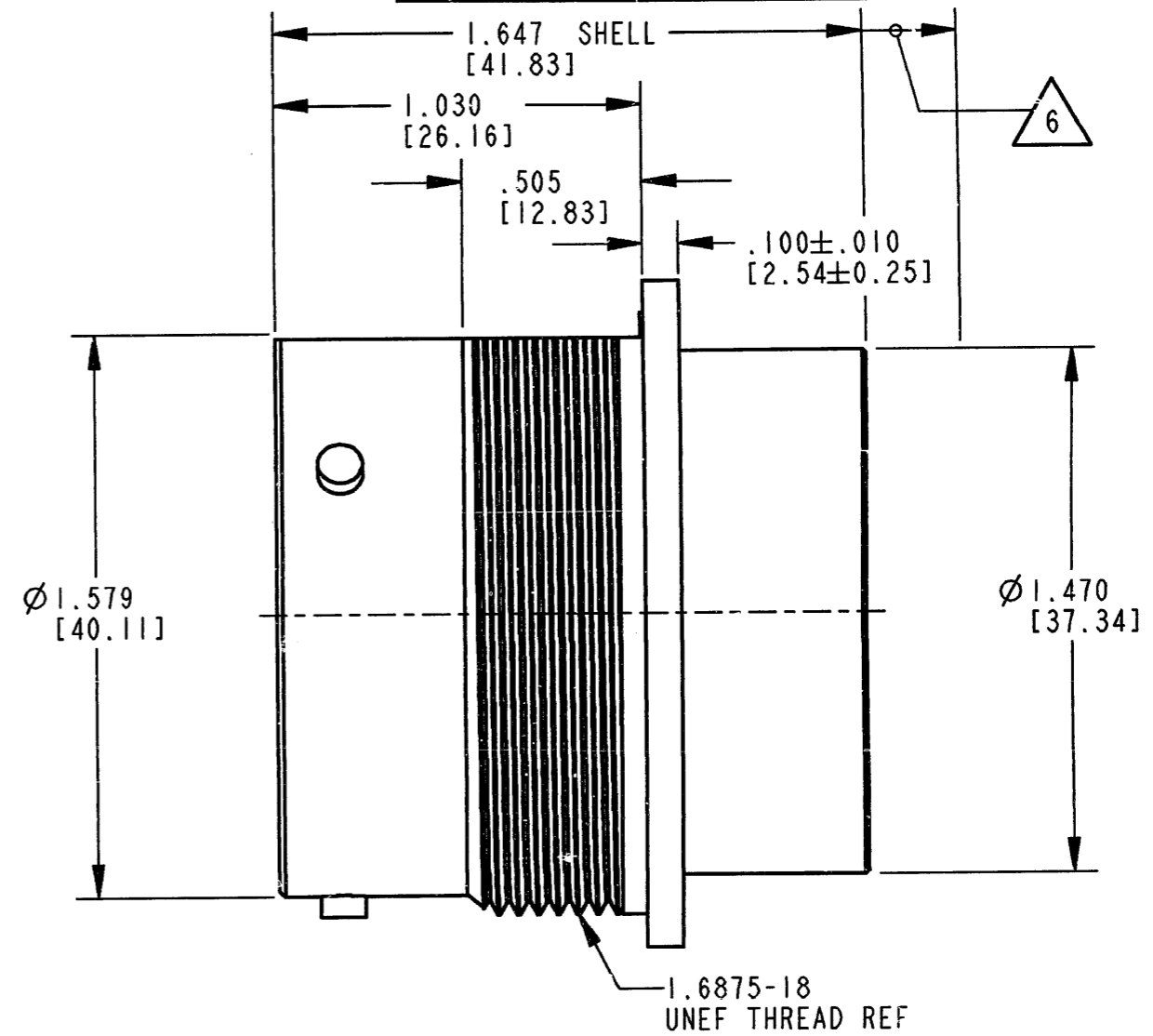
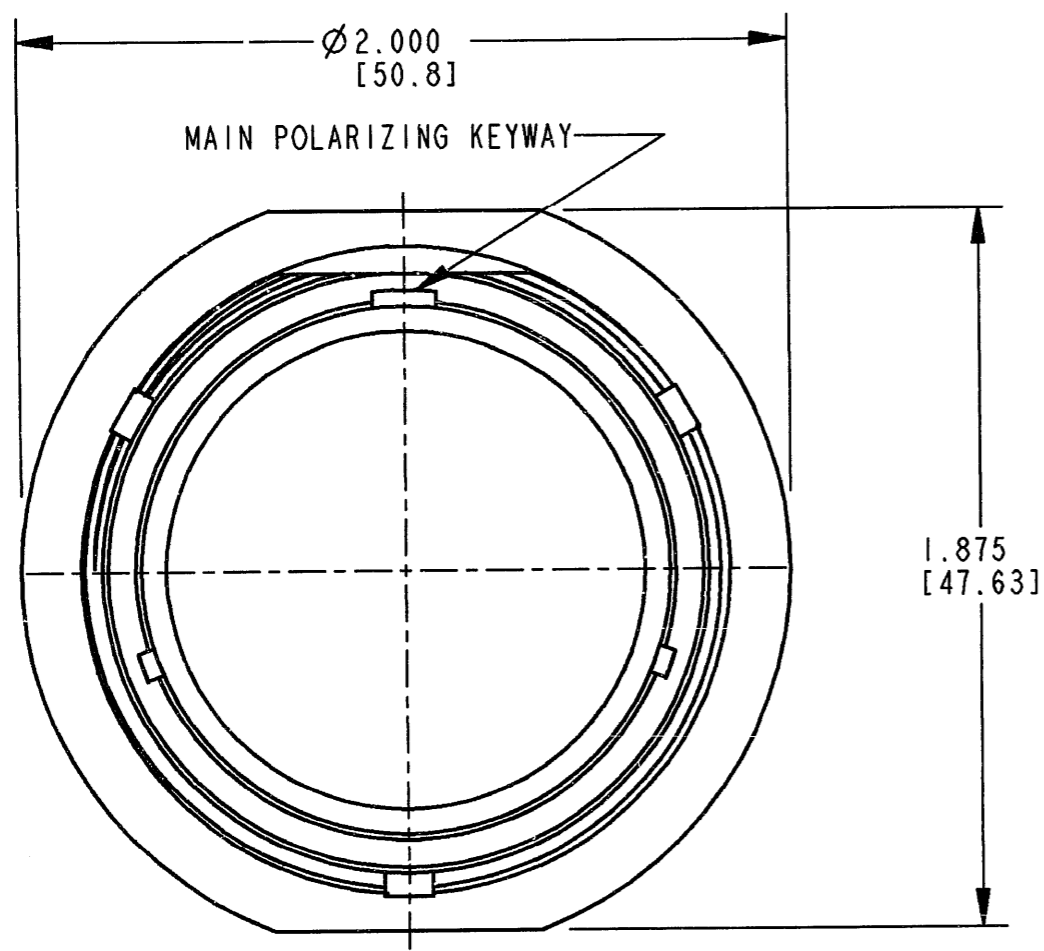

6. TOTAL DIM. WITH EXTENDED WIRE SEAL (WITH CONTACTS #4 OR #8 ONLY) = 1.870 ± .050 [47.50 ± 1.27].

5. FOR CONTACTS AND WIRES PERFORMANCE AND APPLICATION CHARACTERISTICS SEE ENVELOPE DWG. 0425-015-0000.

4. FOR ARRANGEMENT OF CONTACT LOCATION SEE ENVELOPE DRAWING 0425-014-2400.

3. FOR PERFORMANCE AND APPLICATION CHARACTERISTICS SEE ENVELOPE DRAWING 0425-016-0000.

2. DIMENSIONS ARE IN INCHES [MILLIMETERS].

NOTES: 1. CONSULT THE FACTORY FOR ELECTRICAL AND MATERIAL SPECIFICATIONS.

- 9. DIMENSION TOLERANCE: ±.025 [ .63] UNLESS OTHERWISE SPECIFIED.
- 8. THIS PART MATES WITH HD36-24-\*\*\*P/S\*-\*\*\*\*
- 7. PART NUMBER INFO: \*\* = ARRANGEMENT: \* = SEAL TYPE

SIGNATURE & DATE		<b>RECEPTACLE CONNECTOR</b> SHELL SIZE 24 BAYONET COUPLING HD30 SERIES  <b>ENVELOPE</b>	CP	MATL. CODE	
DR	X. SANCHEZ 18APR03		<b>The Deutch Company</b> DEUTSCH I.P.D. 3850 INDUSTRIAL AVE. HEMET, CALIF. 92545		
CHK	Jamie C. Aguilar 5/15/03		<b>B</b>	<b>HD34-24-XP/S*</b>	
PE	D. Kalinski 5/16/03			DWG SIZE	CODE 11139
APPD	Beard 5-20-03		SCALE	NONE	WT