

REV
C HD16-9-1939SE

REVISIONS			
SYM	DESCRIPTION	DATE	APPROVED
NC	NEW RELEASE PER E.O. P15120	10/07/96	R.D.R.
A	REVISED PER E.O. P15192	01/07/97	R.D.R.
B	REVISED PER E.O. P16453	12/17/99	R.D.R.
C	REVISED PER E.O. P17740	4-26-02	RDR

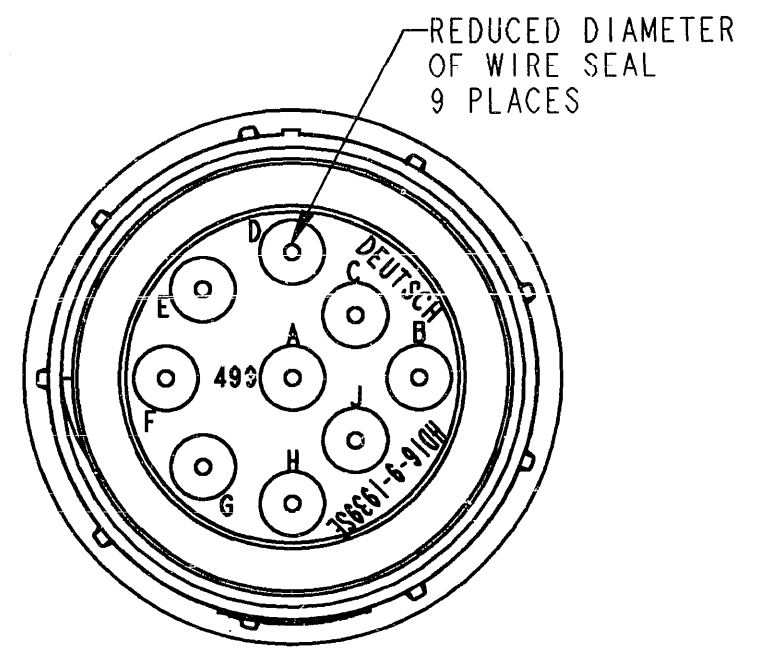
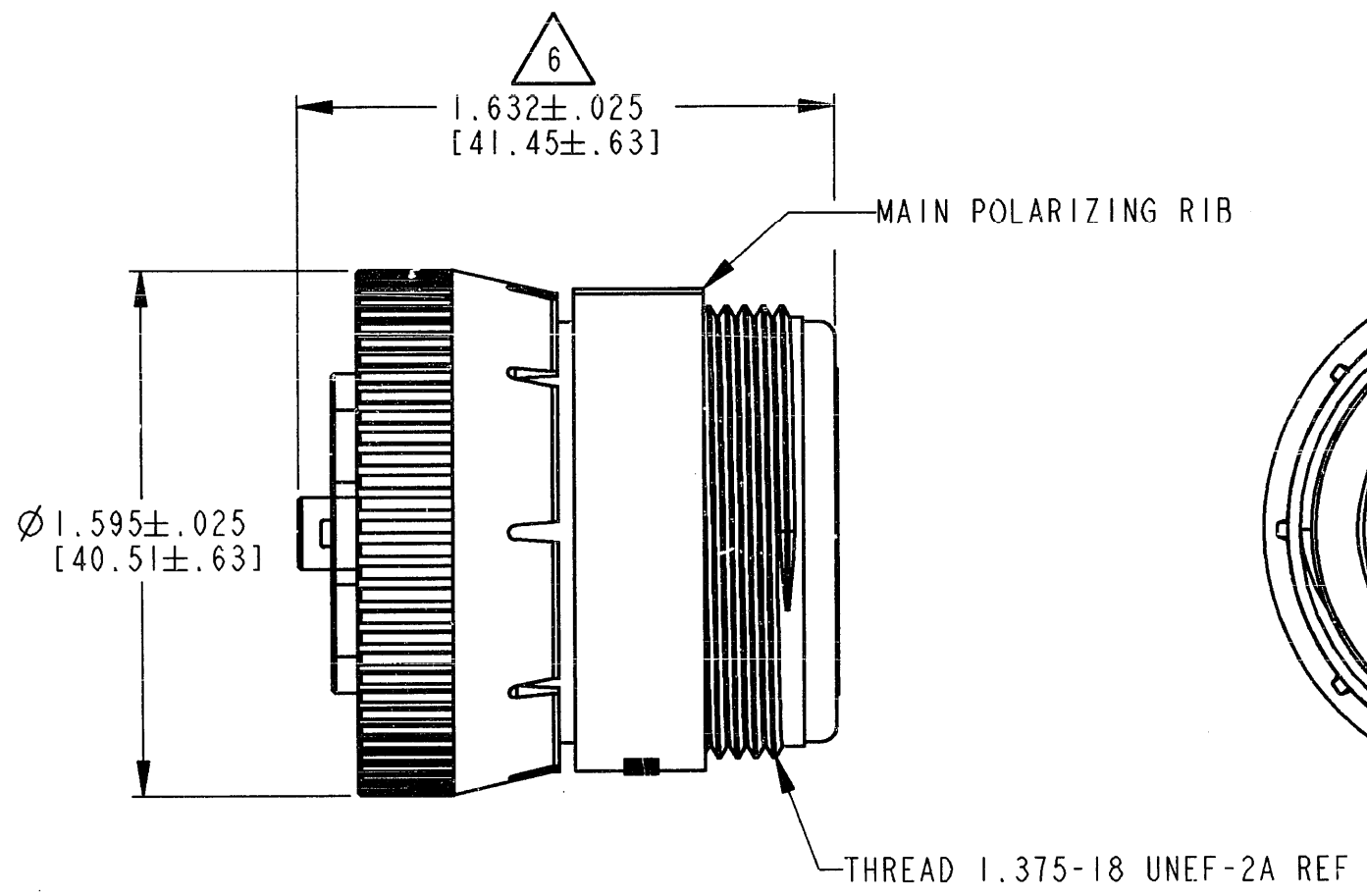
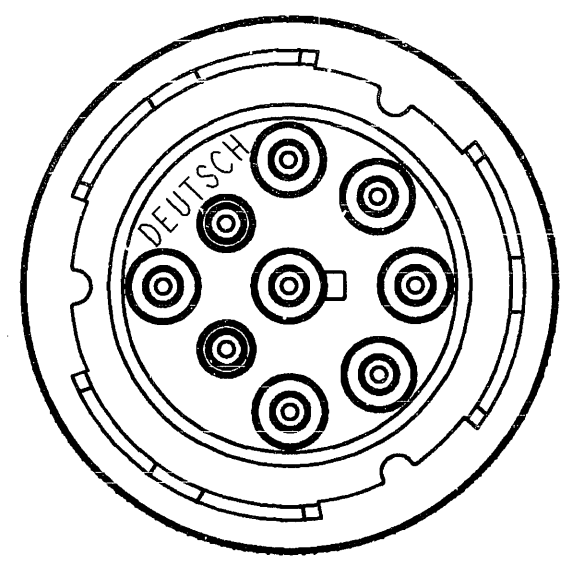

- FOR "PERFORMANCE AND APPLICATION CHARACTERISTICS OF SOLID/STAMPED AND FORMED CONTACTS AND WIRES," SEE ENVELOPE DRAWING 0425-015-0000. THIS PLUG USES SOCKET CONTACTS ONLY.
- ALL DIMENSIONS ARE IN INCHES [MILLIMETERS].
- THIS CONNECTOR SERIES WILL ACCOMMODATE THE FOLLOWING WIRE INSULATION DIAMETERS:

CONTACT SIZE	MINIMUM O.D.	MAXIMUM O.D.
16	.053 [1.35]	.120 [3.05]

- MATERIAL: SHELL : PLASTIC; SEAL : RUBBER.
- OVERALL DIMENSION DOES NOT INCLUDE RUBBER GROMMET.
- THIS PLUG MATES WITH HD10-9-1939P*-**** AND HD14-9-1939P*-**** RECEPTACLES (* = SEAL TYPE, **** = ALL MODIFICATIONS).

NOTES:
1. CONSULT FACTORY FOR ELECTRICAL AND MATERIAL SPECIFICATIONS.

SIGNATURE & DATE	
DR	R. BENEDICT 25-Apr-02
CHK	<i>J. C. [Signature]</i> 4/26/02
PE	<i>S. Beard</i> 4-26-02
APPD	<i>R. Reed</i> 4-26-02
SCALE	NONE WT

PLUG CONNECTOR
HD10 SERIES
ARR. 9-1939
"E" SEAL
COLOR: BLACK

ENVELOPE

CP	MATL. CODE
The Deutsch Company DEUTSCH I.P.D. 3850 INDUSTRIAL AVE. HEMET, CALIF. 92545	
B	HD16-9-1939SE
DWG SIZE	CODE 11133 SHEET OF