



with Clear Duty® Technology

FASCIA LIGHTS - 4"

- EMPS2QM(x)(xxx) - QUICK MOUNT
- EMPS2SMS(x)(xxx) - SCREW MOUNT
- EMPS2STS(x)(xxx) - STUD MOUNT THREADED

FASCIA LIGHTS - 3"

- EMPS1QM(x)(xxx) - QUICK MOUNT
- EMPS1SMS(x)(xxx) - SCREW MOUNT
- EMPS1STS(x)(xxx) - FORD GRILLE MOUNT
- EMPS1SLS(x)(xxx) - STUD MOUNT THREADED

TECHNICAL SPECIFICATIONS				
Dimensions (From Mounting Surface)		4.52"L x 0.92"H x 0.42"D		
4" Screw Mount:		4.04"L x 0.92"H x 0.42"D		
4" Stud, Threaded Mount:		4.04"L x 0.92"H x 0.42"D		
4" Quick Mount:		3.425"L x .092"H x 0.42"D		
3" Screw Mount:		2.9"L x 0.92"H x 0.42"D		
3" Stud, Threaded Mount:		2.9"L x 0.92"H x 0.42"D		
3" Quick Mount:		2.9"L x 0.92"H x 0.47"D		
Input Voltage:		9-32Vdc		
4" CURRENT CONSUMPTION (Amps)				
12.8Vdc		25.6Vdc		
	Peak	Average	Peak	Average
Red	0.62	0.36	0.31	0.18
Amber, Blue, Green or White	0.90	0.60	0.45	0.30
3" CURRENT CONSUMPTION (Amps)				
12.8Vdc		25.6Vdc		
	Peak	Average	Peak	Average
Red	0.62	0.26	0.31	0.13
Amber, Blue, Green or White	0.90	0.38	0.45	0.19
AFTER POWER IS ON , touching the WHITE wire to the ground will allow you to change various settings on the module. (refer to page 8)				

WIRE HOOK-UP TABLE	
WIRE COLOR:	FUNCTION:
RED	Power (Primary)
BLACK	Ground
GREEN**	Sync2 *
WHITE to GROUND	Setup Wire (See pg. 8*)
WHITE to POWER	Function Wire
RED/WHITE	Power (Secondary)

** To sync multiple mPower lights, connect the Green wire from each light together.
 * Will NOT work w/ other sync products such as Ghost, LED3, & 4 wire Intersector w/external flasher.
 *Will Work with Sync 2 products nFORCE Secondary Lights, nFORCE FIT and 5 wire Intersector Lights.

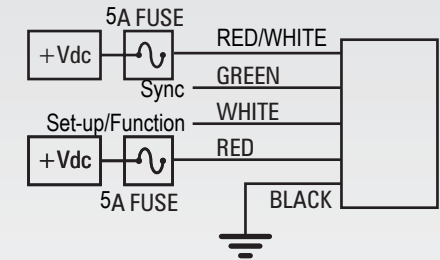

⚠ WARNING

- HIGH CURRENT interconnects must be properly terminated. Poor crimp quality can cause heat build-up and fire. Follow crimp connector manufacturer instructions.
- DO NOT install this product or route any wires in the Air Bag Deployment Zone. Refer to vehicle Owner's Manual for deployment zones.
- Unit may become hot to touch during normal operation.
- Failure to properly install connectors, fuses or wiring may cause vehicle failure or fire.
- Installation must only be performed by trained technician. Installer must determine vehicle wiring configuration and proper integration of system.
- Use proper wire gauge. All power wires connecting to positive (+) or negative (-) battery terminal or local chassis ground (-) must be sized to supply at least 125% of max. current and properly fused at power source.
- Install protective grommets when routing wire through firewall or metal.

NOTICE:

Installers and users must comply with all applicable federal, state and local laws regarding use and installation of warning devices.

*Improper use or installation may void warranty coverage. To review our Limited Warranty Statement & Return Policy for this or any SoundOff Signal product, visit our website at www.soundoffsignal.com/sales-support. If you have questions regarding this product, contact **Technical Services**, Monday - Friday, 8 a.m. to 5 p.m. at 1.800.338.7337 (press #4 to skip the automated message). Questions or comments that do not require immediate attention may be emailed to techservices@soundoffsignal.com.*

⚠ WARNING
 This product contains high intensity LED devices. To prevent eye damage, DO NOT stare into the light beam at close range.



1.800.338.7337 / www.soundoffsignal.com

SUPERIOR CUSTOMER RELATIONSHIPS. SMARTLY DESIGNED LIGHTING & ELECTRONIC SOLUTIONS.

with Clear Duty® Technology

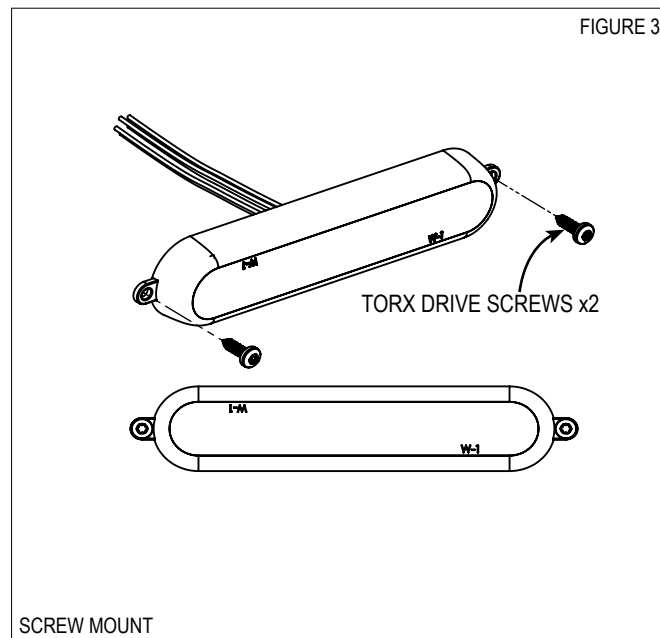
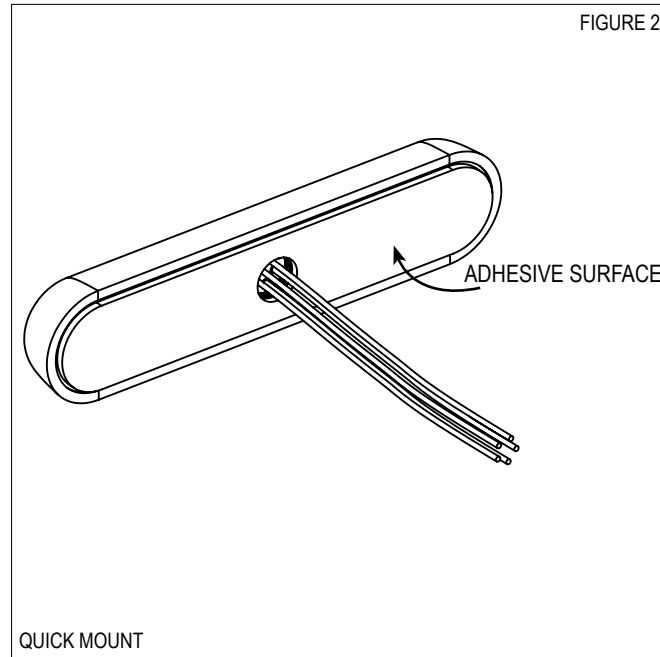
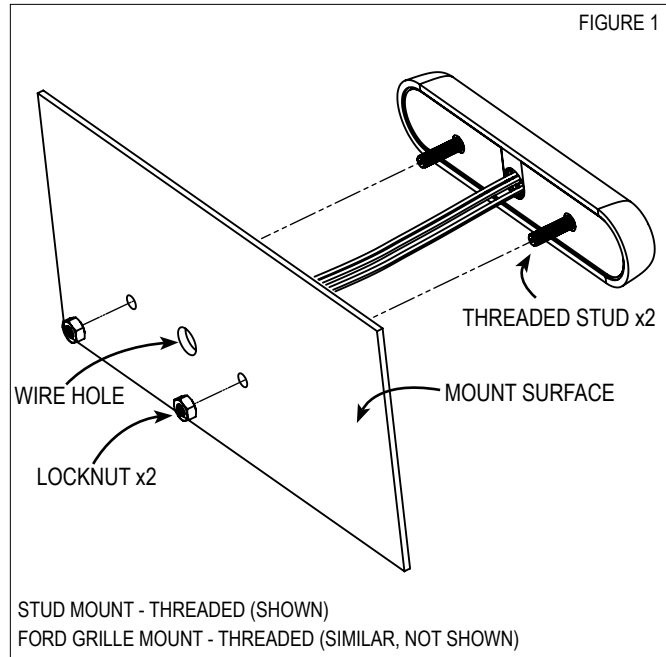

INSTALLATION:

Stud Mount (Figure 1)

1. Pre-Drill per stud mount pattern indicated on page 11 (3") or per the supplied mounting template (4").
2. Clean the surface as required.
3. Deburr hole as required.
4. Make wire connections and feed wire through the drilled wire hole.
5. Install light, inserting 2 studs into the 2 drilled holes.
6. Install 2 lock nuts onto studs behind mount surface.
Hand tighten only until mount surface and light are flush.

Quick Mount (Figure 2)

1. Pre-Drill per quick mount pattern indicated on page 10 (4") or page 11 (3"). (Wire hole only).
2. Deburr hole as required.
3. Clean surface with supplied alcohol wipe.
4. Make wire connection and feed wire through the drilled wire hole.
5. Remove adhesive backer and align light into desired position. Apply to surface and hold firmly for 30 seconds. **CAUTION! APPLY UNIFORM PRESSURE ACROSS FULL FACE OF LIGHT.**

Screw Mount (Figure 3)

1. Pre-Drill per screw mount pattern indicated on page 10 (4") or page 11 (3").
2. Deburr and clean the surface as required.
3. Make wire connections and feed the wire through the drilled wire hole.
4. Install light with 2x Torx drive screws and hand tighten only until mount surface and light are flush.

with Clear Duty® Technology

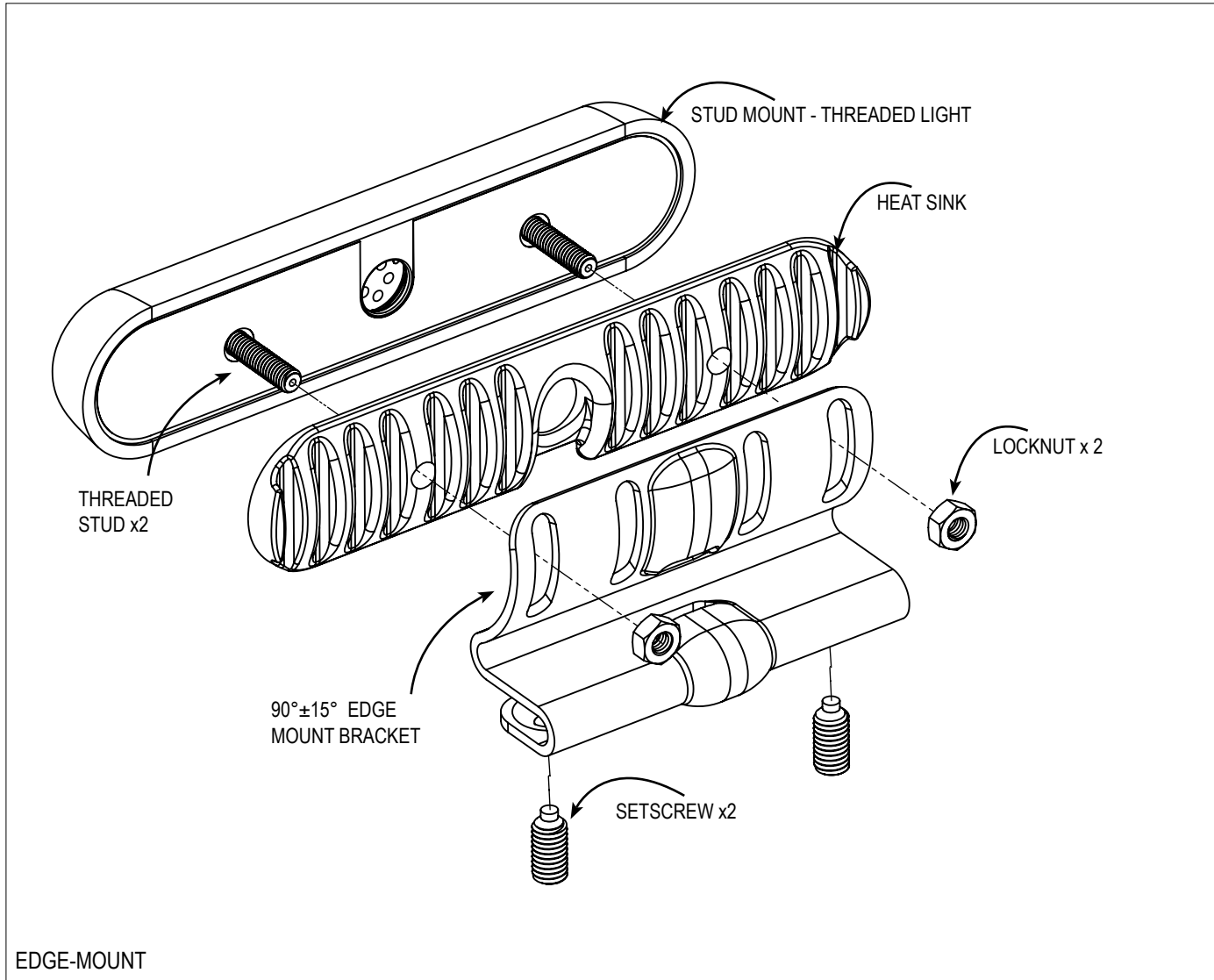

INSTALLATION:

Edge-Mount Bracket

1. Install Heat Sink onto "mPOWER Stud Mount, Threaded" light as indicated. Wire passed through center hole.
2. Install bracket onto "mPOWER Stud Mount, Thread" light as indicated. Wire passed through rear relief and into lower edge grip relief.
3. Install 2 lock nuts onto "mPOWER Stud Mount, Thread" light. Hand tighten until final adjustment.
4. Place bracket over desired vehicle's edge surface (i.e. rear hood), ensure wire is fully seated in rear relief, wrapping around edge lying flat.
5. Tighten 2 setscrews to vehicle's edge surface.
6. Adjust angle of light to desired direction and tighten 2 lock nuts until secure.
7. Make wire connections.

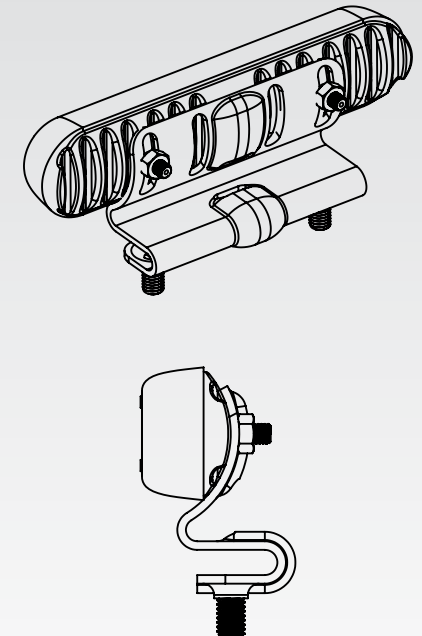

with Clear Duty® Technology

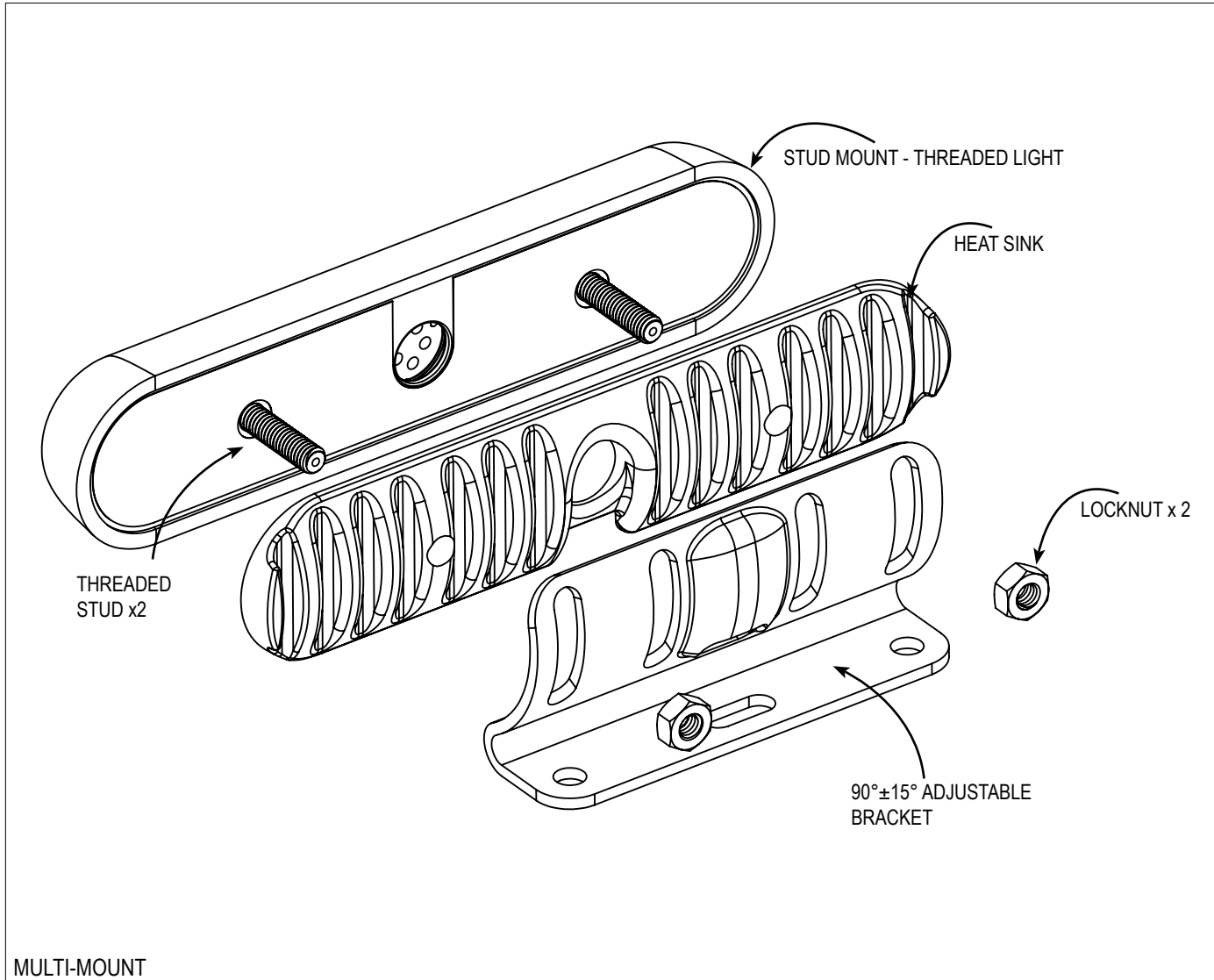

INSTALLATION:

Multi-Mount Bracket

1. Pre-drill mount holes as required (bracket holes and spacing are indicated on page 10 (4") or page 11 (3")).
2. Place bracket onto desired vehicle's surface and secure with screws (not provided).
3. Install Heat Sink onto "mPOWER Stud Mount, Threaded" light as indicated. Wire passes through center hole.
4. Install "mPOWER Stud Mount, Thread" light onto bracket as indicated. Wire passes through rear relief.
5. Install 2 lock nuts onto "mPOWER Stud Mount, Thread" light as indicated. Hand tighten until final adjustment.
6. Adjust angle of light to desired direction and tighten 2 lock nuts until secure.
7. Make wire connections.

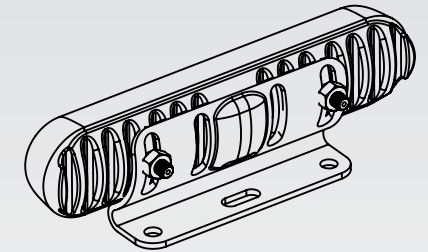

with Clear Duty® Technology

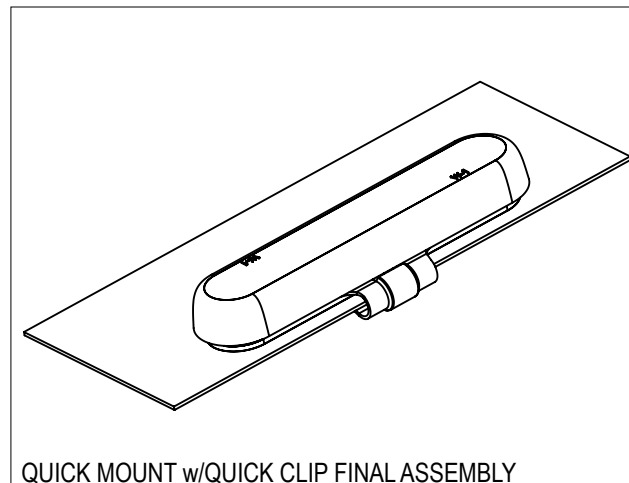
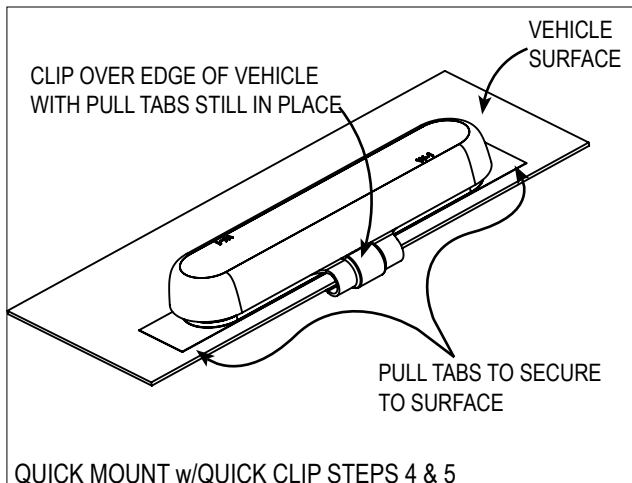
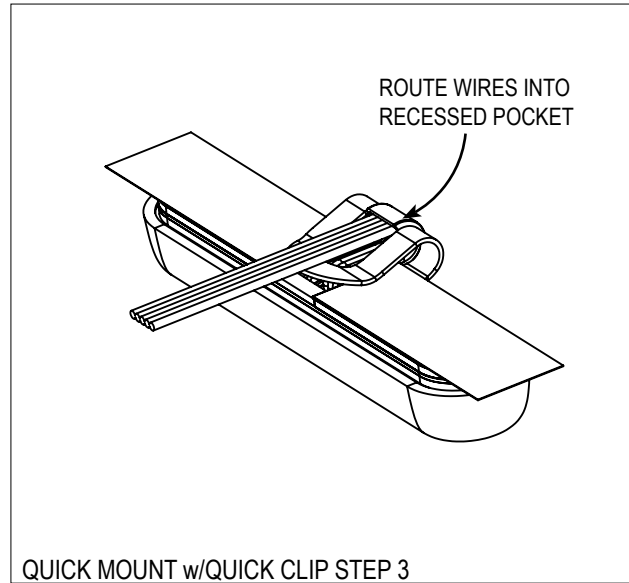
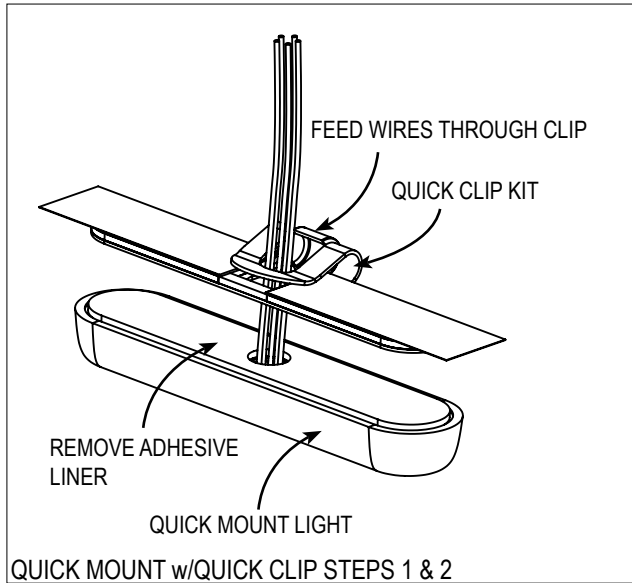

INSTALLATION:

Quick Mount w/Quick Clip

1. Prep surface with supplied alcohol wipe.
2. Feed wires through quick clip as shown.
3. Remove adhesive liner on the light and install clip to light. Make sure to properly align ends before placing down.
4. Route wires into recessed pocket lying flat in pocket.
5. With red pull tabs still in place, clip light over edge of vehicle surface. Be careful to make sure red pull tabs **DO NOT PEEL, FOLD UNDER OR WRINKLE**. Make sure wire is lying flat and is not pinched.
6. With light properly oriented, pull red tabs to secure light to surface.
7. Make wire connections.

FOR USE WITH STUD MOUNT MPOWERS® ONLY

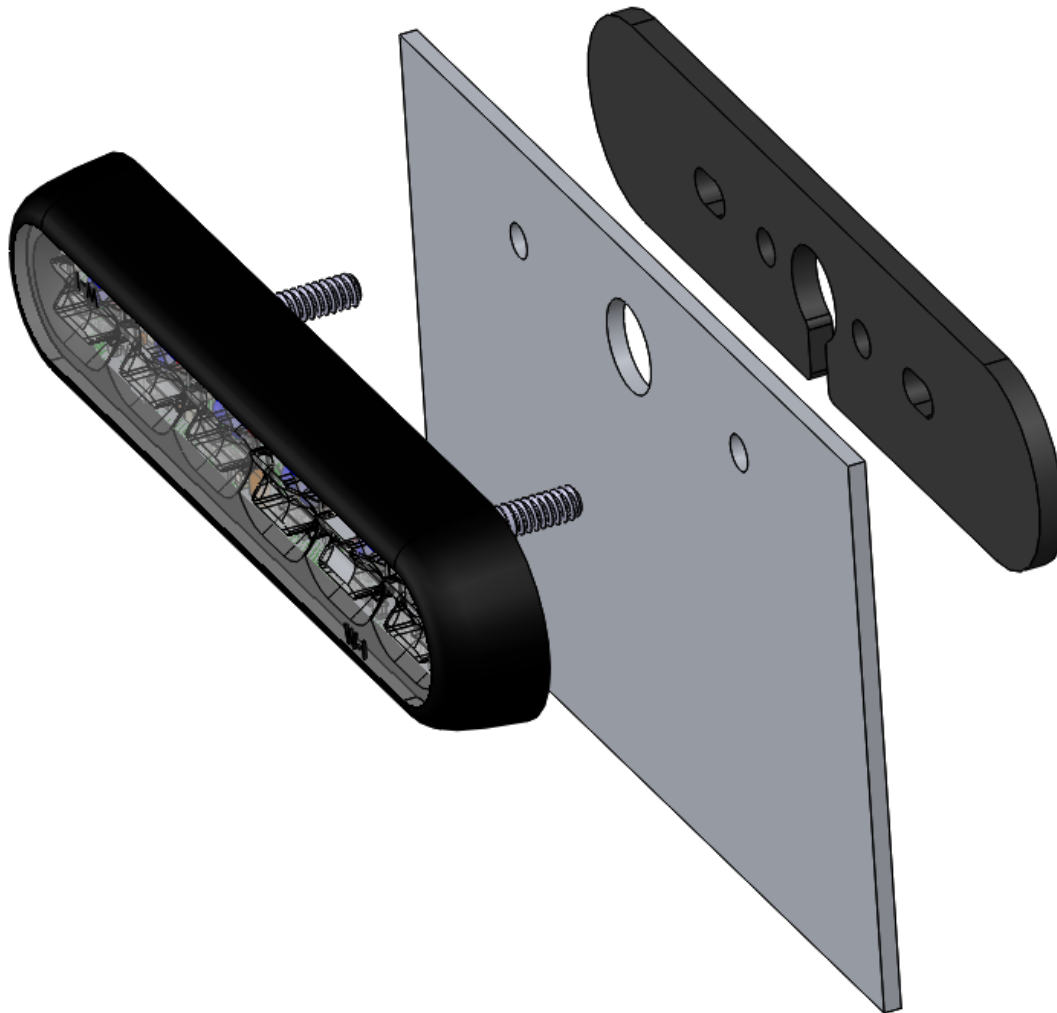

GRILLE MOUNT BACK PLATE (PMP2BKGBP)

INSTALLATION:

Grille Mount Back Plate (PMP2BKGBP)

1. Find placement for mPower® light location.
2. Use the Stud Mount templates on Page 11, for a 4" mPower® light, or Page 12, for a 3" mPower® light. Drill 3 holes in the location of the new mPower. These holes will be for the mPower studs and wires.
3. Feed the wires through the wire exit hole first. Then push the studs through.
4. Put the back plate on the outer side of the surface you drilled into. Then put the nuts onto the studs and tighten down.



with Clear Duty® Technology

OVER-VOLTAGE PROTECTION

When an over-voltage condition is detected, the module will flash an over-voltage warning pattern of 50mS ON/950mS OFF to alert of the over-voltage condition and protect the electronics from damage due to heat/voltage.

THERMAL COMPENSATION PROTECTION

The LED module is designed to provide maximum power output while providing protection to the electronic components by reducing the output power at extreme temperatures.

SYNC 2

Synchronizing the flashing of multiple light modules is accomplished by connecting the Green wires of different light modules together. Up to 24 light modules can be connected for synchronized flashing. All light module flash patterns must be set to the same flash pattern # to ensure proper operation. Refer to the Sequence Type section in Set-Up Table (page 8) to setup light modules to flash in alternate or simultaneous flash pattern. NOTE: Will NOT work with non-Sync 2 products such as Ghost, LED3, and 4 wire Intersector. WILL WORK with Sync 2 products nFORCE Secondary Lights, nFORCE FIT and 5 wire Intersector Lights.

FLASH PATTERNS			
PATTERN #	SINGLE COLOR	DUAL COLOR	TRI-COLOR
1		QUINT	
2		WARP	
3		INTER-CYCLE	
4		DOUBLE	
5		QUAD	
6		POWER PULSE	
7		ROAD RUNNER	
8		Q-SWITCH	
9		STEADY-BURN / ROADRUNNER (SEQUENCE TYPE 1: STEADY BURN, SE- QUENCE TYPE 2: ROADRUNNER)	
10		STEADY-BURN DRIVER TITLE 13 QUAD (SEQUENCE TYPE 1: STEADY BURN, SE- QUENCE TYPE 2: TITLE 13 QUAD)	
11		QUAD 2	
12		DOUBLE 2	
13			RANDOM 1
14			RANDOM 2



1.800.338.7337 / www.soundoffsignal.com



with Clear Duty® Technology

FUNCTION TABLES

Changing the function table is only enabled when the LED module is in a flashing mode (disabled in cruise or steady ON functions). The functional operation of the LED module can be changed while applying the +V to the Red wire with the black wire connected to ground. When the light is flashing, momentarily connect the White wire to ground for >4S and <5S (light will go steady high, steady low, off, steady high, steady low) then release. The function table will now advance to the next table (table 1 to table 2, table 2 to table 3, or table 3 to table 1). Repeat above process until required function table is active.

FUNCTION TABLE 1					
WIRE			LIGHT		
RED	R/W	WHT	SINGLE	DUAL	TRI
+9-32V			FLASH	FLASH DUAL	FLASH TRI
	+9-32V		CRUISE	STEADY CLR 2	STEADY CLR 3
+9-32V	+9-32V		FLASH	STEADY CLR 2	STEADY CLR 3
		+9-32V	NO OP	NO OP	NO OP
+9-32V		+9-32V	LOW PWR FLASH	FLASH CLR 1	FLASH CLR 1
	+9-32V	+9-32V	CRUISE	FLASH CLR 2	FLASH CLR 2
+9-32V	+9-32V	+9-32V	LOW PWR FLASH	FLASH DUAL	FLASH CLR 3

FUNCTION TABLE 2					
WIRE			LIGHT		
RED	R/W	WHT	SINGLE	DUAL	TRI
+9-32V			FLASH	FLASH CLR 1	FLASH DUAL
+9-32V		+9-32V	CRUISE	FLASH DUAL	FLASH TRI
	+9-32V		STEADY CLR 1	STEADY CLR 2	STEADY CLR 3
	+9-32V	+9-32V	STEADY CLR 1	STEADY CLR 2	STEADY CLR 3
+9-32V	+9-32V	+9-32V	STEADY CLR 1	STEADY CLR 2	STEADY CLR 3
		+9-32V	NO OP	NO OP	NO OP
+9-32V	+9-32V		STEADY CLR 1	STEADY CLR 2	STEADY CLR 3

FUNCTION TABLE 3					
WIRE			LIGHT		
RED	R/W	WHT	SINGLE	DUAL	TRI
+9-32V			FLASH	FLASH DUAL	FLASH TRI
	+9-32V		FLASH LOW PWR	FLASH DUAL LOW PWR	FLASH TRI LOW PWR
+9-32V	+9-32V		FLASH LOW PWR	FLASH DUAL LOW PWR	FLASH TRI LOW PWR
		+9-32V	NO OP	NO OP	NO OP
+9-32V		+9-32V	FLASH LOW PWR	FLASH DUAL LOW PWR	FLASH TRI LOW PWR
	+9-32V	+9-32V	FLASH LOW PWR	FLASH DUAL LOW PWR	FLASH TRI LOW PWR
+9-32V	+9-32V	+9-32V	FLASH LOW PWR	FLASH DUAL LOW PWR	FLASH TRI LOW PWR



1.800.338.7337 / www.soundoffsignal.com



with Clear Duty® Technology

COLOR SWAP

This function is only valid for dual and tri-color light modules and can only be changed when the light module is in a flashing mode (disabled for single color modules and when light module is operating in cruise or steady ON functions). When the light is flashing, momentarily connect the white wire to ground for >2S and <3S (light will go steady high, steady low, off) then release. The light module will switch between Color Swap OFF and Color Swap ON. When Color Swap is OFF, the 1st color will flash 1st on a dual/tri color pattern. When Color Swap is ON, the 2nd color will flash 1st on a dual/tri color pattern.

SIMULTANEOUS/ALTERNATE

This function can only be changed when the LED module is in a flashing mode (disabled in cruise or steady ON functions) and only has an effect when at least 2 LED modules have the green sync wire connected together. When the light is flashing, momentarily connect the white wire to ground for >3S and <4S (light will go steady high, steady low, off, steady high) then release. The light module will switch between Simultaneous and Alternate each time this sequence is done. To have light modules flash simultaneously, both light modules need to be set to the same sequence type (Set-Up Table). To have light modules flash alternately, the light modules need to be set to different sequence types (Set-Up Table).

ADVANCE PATTERN

Flash pattern can only be changed when the LED module is in a flashing mode (disabled in cruise or steady ON functions). When the light is flashing, momentarily connect the white wire to ground for >250mS and <1S (light will go steady high) then release. The flash pattern will advance to the next pattern. If the light module was at the last pattern, the pattern will reset to the 1st pattern.

BACKUP PATTERN

This function is only valid when the LED module is in a flashing mode (disabled in cruise or steady ON functions). When the light is flashing, momentarily connect the white wire to ground for >1S and < 2S (light will go steady high, steady low) then release. The flash pattern will backup to the previous pattern. If the light module was at the first pattern, the pattern will change to the last pattern on the list.

PATTERN RESET

This function is only valid when the LED module is in a flashing mode (disabled in cruise or steady ON functions). When the light is flashing, momentarily connect the white wire to ground for >5S and <6S (light will go steady high, steady low, off, steady high, steady low, off) then release. The flash pattern will reset to the 1st pattern in the list.

FACTORY RESET

This function is only valid when the LED module is in a flashing mode (disabled in cruise or steady ON functions). When the light is flashing, momentarily connect the white wire to ground for >6S and <7S (light will go steady high, steady low, off, steady high, steady low, off, steady high) then release. The LED module will reset to: pattern=1, Function Table=1, Color Swap=OFF, Simultaneous.

SETUP TABLE			
SECONDS		USER INTERFACE	
FROM	TO	VISUAL FEEDBACK	ACTION TAKEN
0	1	STEADY-HIGH (60%)	FORWARD ONE PATTERN
1	2	STEADY-LOW (30%)	BACKWARD ONE PATTERN
2	3	OFF	COLOR SWAP (OFF OR ON)
3	4	STEADY - HIGH (60%)	SEQUENCE TYPE: SIMULTANEOUS OR ALTERNATE
4	5	STEADY - LOW (30%)	SEE FUNCTION TABLE
5	6	OFF	RESET TO PATTERN 1
6	7	STEADY-HIGH (60%)	FACTORY RESET (PATTERN 1, COLOR SWAP: OFF, SIMULTANEOUS) SEPARATE COLOR CONTROL: OFF
If held longer than 7 seconds, the light will go back to flashing the current pattern and no action will be taken.			



1.800.338.7337 / www.soundoffsignal.com



with Clear Duty® Technology

REMOTE MODE: FOR USE WITH bluePRINT SYSTEM ONLY

Connecting the Green wire to ground before applying power to the Red or Red/White wires will place the LED module into remote mode and the light output color will be directly controlled by the input wires as shown below.

For Cruise mode or Low Power control of the LED module, the signal to the control wires must be 100 +/- 2Hz using the duty cycle inputs listed below to produce the light output.

mpower® Secondary LED Light Remote Mode Functionality							
Red Wire	Red/Wht Wire	Single Color		Dual Color		Tri Color	
		Color Swap=OFF	Color Swap=ON	Color Swap=OFF	Color Swap=ON	Color Swap=OFF	Color Swap=ON
Cruise	-	Cruise Color 1		Cruise Color 1	Cruise Color 2	Cruise Color 1	Cruise Color 2
-	Cruise			Cruise Color 2	Cruise Color 1	Cruise Color 2	Cruise Color 1
Cruise	Cruise			Cruise Color 2	Cruise Color 1	Cruise Color 3	Cruise Color 3
Flash	-	Flash Color 1		Flash Color 1	Flash Color 2	Flash Color 1	Flash Color 2
-	Flash			Flash Color 2	Flash Color 1	Flash Color 2	Flash Color 1
Flash	Flash			Flash Color 2	Flash Color 1	Flash Color 3	Flash Color 3
Steady ON	-	Steady ON Color 1		Steady ON Color 1	Steady ON Color 2	Steady ON Color 1	Steady ON Color 2
-	Steady ON			Steady ON Color 2	Steady ON Color 1	Steady ON Color 2	Steady ON Color 1
Steady ON	Steady ON			Steady ON Color 2	Steady ON Color 1	Steady ON Color 3	Steady ON Color 3
Cruise	Flash			Flash Color 2/Cruise Color 1 during OFF cycle of Flash	Flash Color 1/Cruise Color 2 during OFF cycle of Flash		
Cruise	Steady ON			Steady ON Color 2	Steady ON Color 1		
Flash	Steady ON			Steady ON Color 2	Steady ON Color 1		

Cruise Mode Duty Cycle (@ 100Hz)	
Input	Light Output
40%	OFF
50%	5%
60%	10%

Low Power Flash D.C. (@ 100Hz)	
Input	Light Output
70%	30%
80%	40%
90%	50%



1.800.338.7337 / www.soundoffsignal.com

FASCIA LIGHTS - 4"

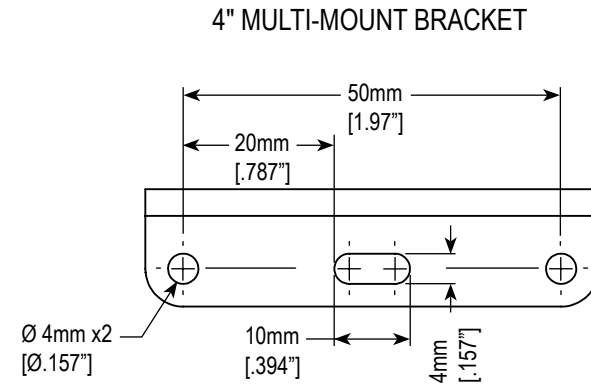
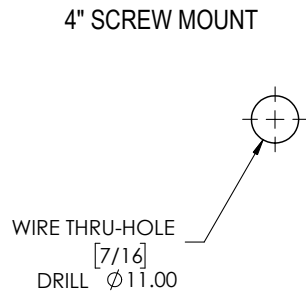
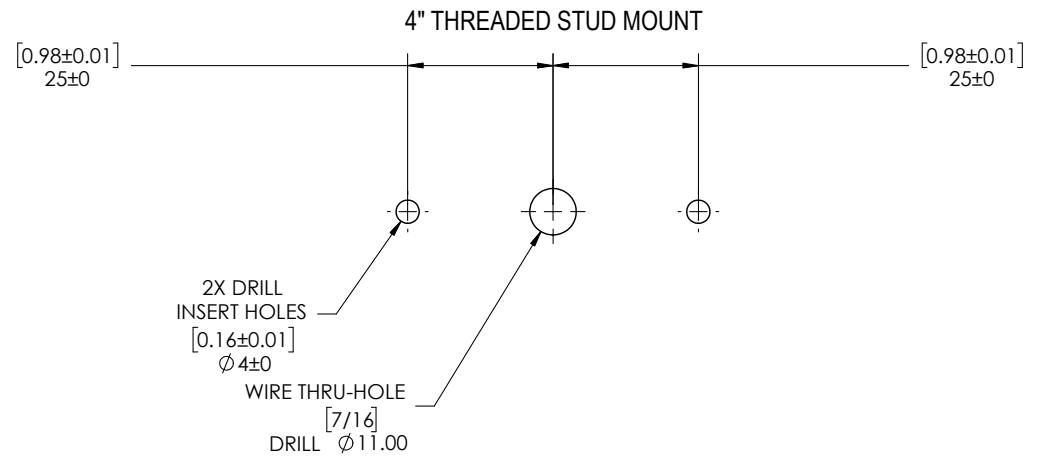
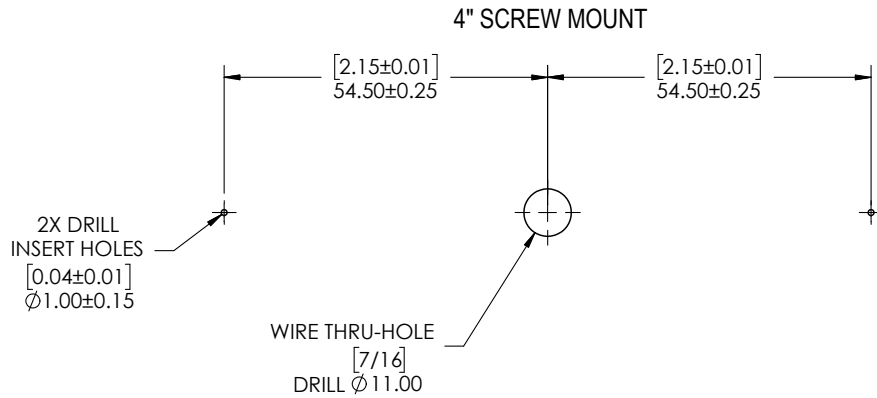

IMPORTANT NOTE:

Due to variations in the printing process and environmental factors, the sizes shown may not be accurate. If this document is used as a cutting template, it is the installers responsibility to confirm the accuracy of the dimensions shown and adjust accordingly.

FASCIA LIGHTS - 3"

3" SCREW MOUNT

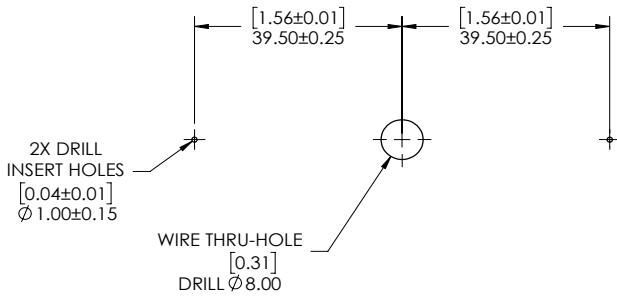

3" MULTI-MOUNT BRACKET

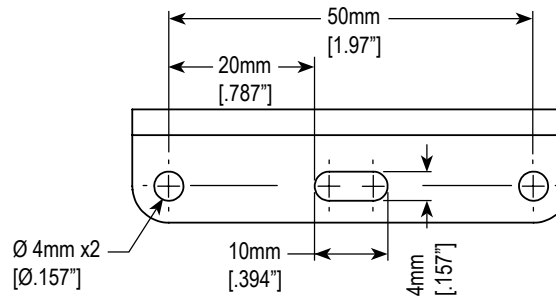

3" SCREW MOUNT

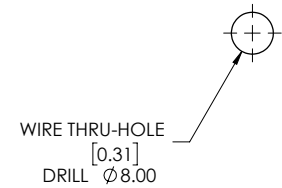

3" FORD GRILLE MOUNT

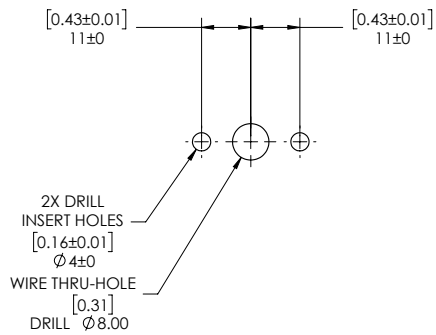

3" STUD MOUNT

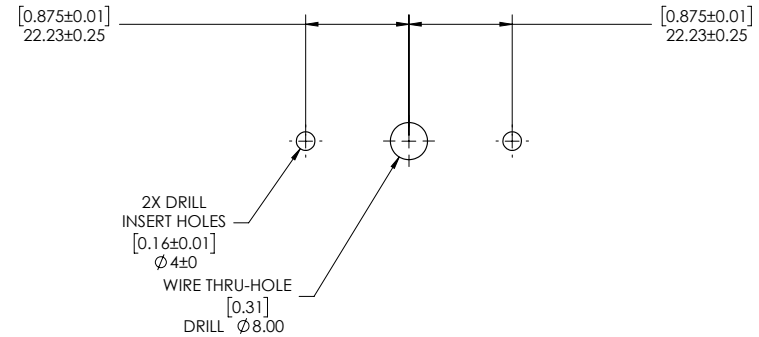

IMPORTANT NOTE:

Due to variations in the printing process and environmental factors, the sizes shown may not be accurate. If this document is used as a cutting template, it is the installers responsibility to confirm the accuracy of the dimensions shown and adjust accordingly.