

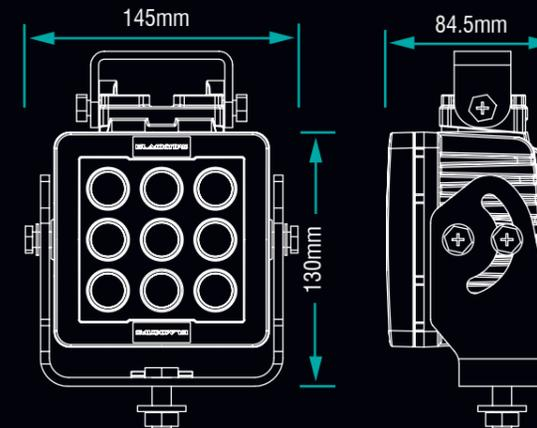

DIMENSIONS



FEATURES & BENEFITS

The Blacktips 9 LED offers outstanding light output in a functional design which can be easily adjusted, with either of the supplied trunnion or single bolt bracket options. High quality construction and components enable Blacktips to withstand vibration up to 21 Grms.

Built-in reverse polarity protection helps prevent accidental damage caused by incorrect installation.

Electronic thermal management ensures that if the light is subjected to a massive heat overload, that a self protection protocol is engaged to reduce the light output, until such time as the heat overload retreats to normal parameters.

Blacktips' LED work light range is a high quality, versatile range designed for Industrial applications such as rigid truck bodies, utility vehicles, emergency & rescue vehicles, cranes and more.

SPECIFICATIONS

LEDs	9 x 7W Cree
Light Colour Temp	5700K
Effective Lumens	5734
Raw Lumens	7200
Voltage	9-32V
Amperage	5.26A @ 12V
Wattage	63W
Connector	Deutsch DT04-2P
Bracket Type	Trunnion & Single Bolt
Weight	1.80kg / 3.96lb
Width	145mm / 5.70"
Height	130mm / 5.11"
Depth	84.5mm / 3.32"
IP Rating	IP69K
Vibration Rating	21.2 Grms
EMC Approval	CISPR25 Class 1 / CE Approved
Lens Material	5mm Polycarbonate
Housing Material	Aluminium
Housing Coating	Marine Grade Anti-Corrosive

BEAM PATTERNS



Part No. BLB070925

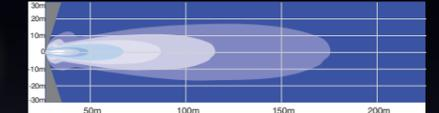

Part No. BLB070940

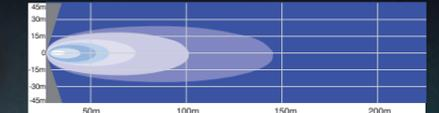

Part No. BLB070960

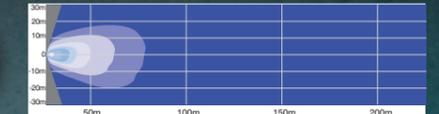

Part No. BLB070990

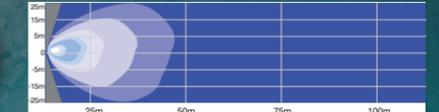

Part No. BLB07093065

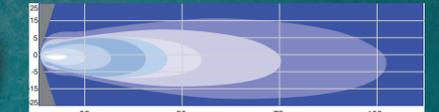

9 LED WORK LIGHT

- Outstanding Light Output
- 4 Mounting Configurations
- CISPR 25 & IP69K Rated
- CE Approved
- Marine Grade Anti-Corrosive Coating

