

A1(420x297)

VXQF 405-4(Rev.1)

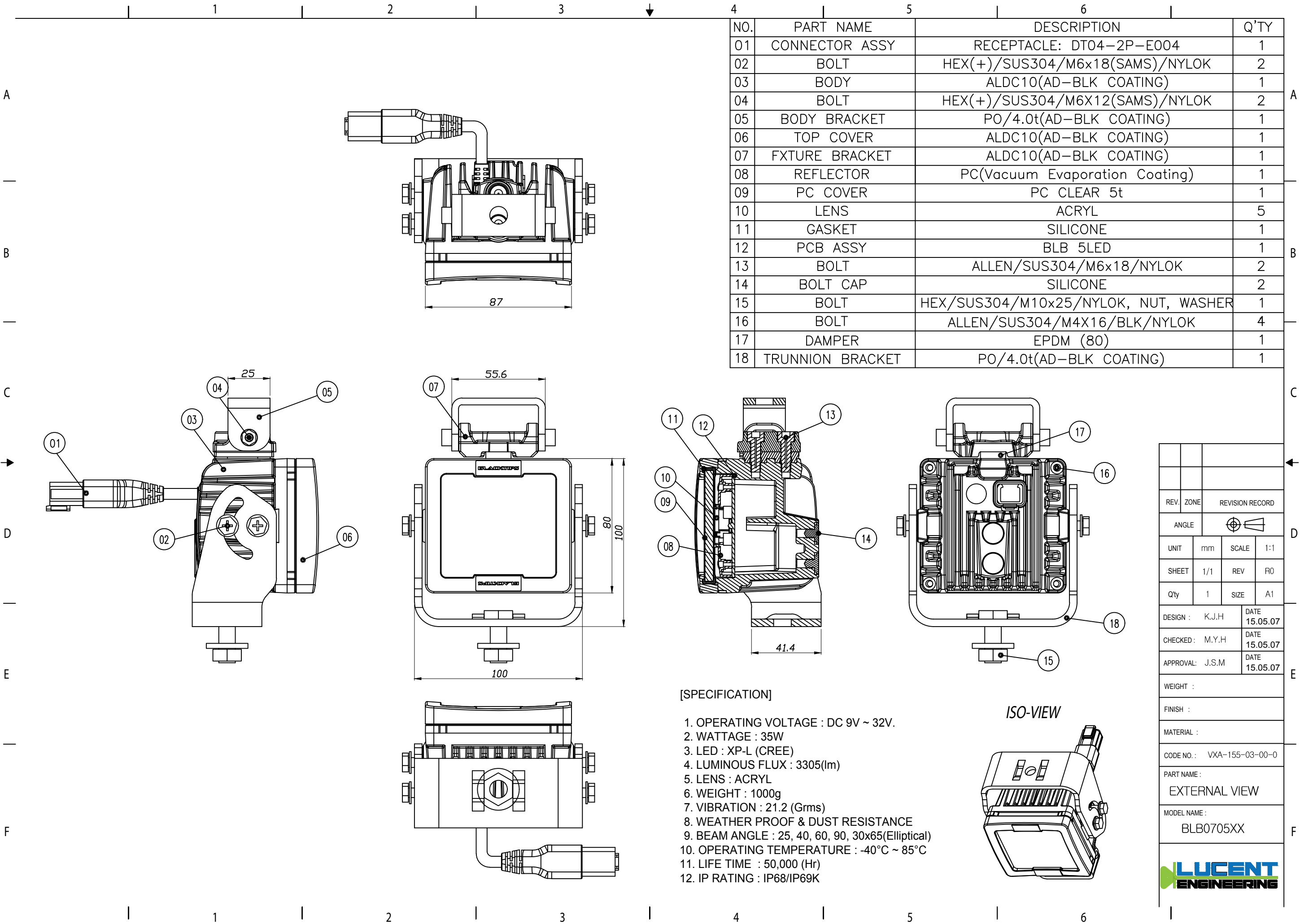

NO.	PART NAME	DESCRIPTION	Q'TY
01	CONNECTOR ASSY	RECEPTACLE: DT04-2P-E004	1
02	BOLT	HEX(+)/SUS304/M6x18(SAMS)/NYLOK	2
03	BODY	ALDC10(AD-BLK COATING)	1
04	BOLT	HEX(+)/SUS304/M6X12(SAMS)/NYLOK	2
05	BODY BRACKET	PO/4.0t(AD-BLK COATING)	1
06	TOP COVER	ALDC10(AD-BLK COATING)	1
07	FXTURE BRACKET	ALDC10(AD-BLK COATING)	1
08	REFLECTOR	PC(Vacuum Evaporation Coating)	1
09	PC COVER	PC CLEAR 5t	1
10	LENS	ACRYL	5
11	GASKET	SILICONE	1
12	PCB ASSY	BLB 5LED	1
13	BOLT	ALLEN/SUS304/M6x18/NYLOK	2
14	BOLT CAP	SILICONE	2
15	BOLT	HEX/SUS304/M10x25/NYLOK, NUT, WASHER	1
16	BOLT	ALLEN/SUS304/M4X16/BLK/NYLOK	4
17	DAMPER	EPDM (80)	1
18	TRUNNION BRACKET	PO/4.0t(AD-BLK COATING)	1

[SPECIFICATION]

1. OPERATING VOLTAGE : DC 9V ~ 32V.
2. WATTAGE : 35W
3. LED : XP-L (CREE)
4. LUMINOUS FLUX : 3305(lm)
5. LENS : ACRYL
6. WEIGHT : 1000g
7. VIBRATION : 21.2 (Grms)
8. WEATHER PROOF & DUST RESISTANCE
9. BEAM ANGLE : 25, 40, 60, 90, 30x65(Elliptical)
10. OPERATING TEMPERATURE : -40°C ~ 85°C
11. LIFE TIME : 50,000 (Hr)
12. IP RATING : IP68/IP69K

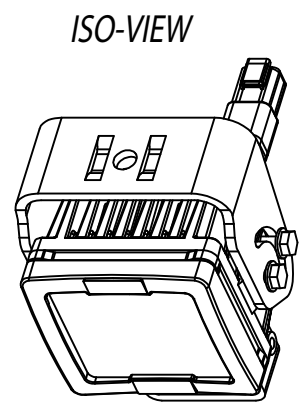

REV.	ZONE	REVISION RECORD	
		ANGLE	
UNIT	mm	SCALE	1:1
SHEET	1/1	REV	R0
Q'ty	1	SIZE	A1
DESIGN :	K.J.H	DATE	15.05.07
CHECKED :	M.Y.H	DATE	15.05.07
APPROVAL :	J.S.M	DATE	15.05.07
WEIGHT :			
FINISH :			
MATERIAL :			
CODE NO. : VXA-155-03-00-0			
PART NAME : EXTERNAL VIEW			
MODEL NAME : BLB0705XX			

