

Heavy Duty Work Lights

ABL 500 LED 850

- designed to exceed everyday demands in all applications
- stringent engineering and testing practices
- highest efficiency and durability in the harshest conditions



ABL
lights group

Premium lighting solutions



Heavy Duty - Work Lights

ABL 500 LED 850

The ABL 500 LED series work lights are designed to exceed everyday demands in all applications. Through stringent engineering and testing practices, we ensure the highest efficiency and durability in even the harshest operating conditions.

Dimensions

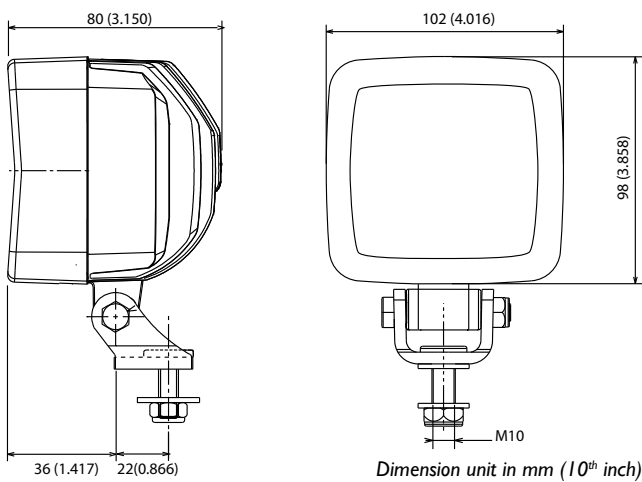

Dimension unit in mm (10th inch)



Light Patterns

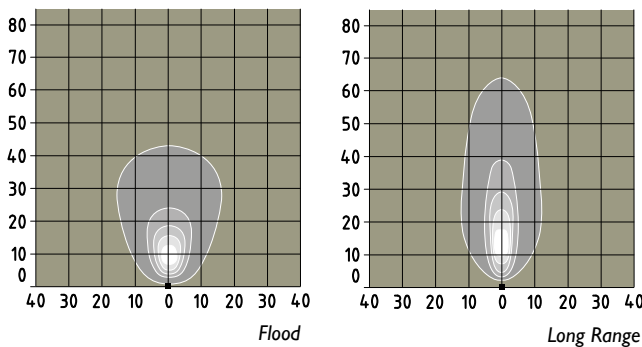

Specifications

Bulb	12 LED - 850 Lumen
Lifetime	20 000 hours
Color temperature	6000°K
Light pattern	Flood, Long Range
Consumption	11 W
Voltage	Multi 12-24V
Intensity	0,46 Amp @ 24Vdc
Weight	0,9 Kg
Vibration resistance	15 Grms from 24 to 2000Hz
Shock resistance	60 G
EMC	ISO 13 766 - ISO 14 982 - ISO 12 895
Load Dump	36V continuous 72V 100 ms 1800 V 50 µs
Polarity	protected against reverse voltage
Electronic Thermal Management	full output @ +35°C ambient 25% dimmed @ +50°C ambient
Water Tightness	IP 68 - IP 69K
Operating Temp	-40°C to +85°C
Salt Spray	ISO 9227
Lens	hardened glass
Reflector	free form reflector
Warranty	20 000 operating hours or 4 years

Connection



Built-in AMP 2 ways

Built-in DT 2 ways

Options



Double Magnetic base

Amber plastic

Red Plastic

Blue Plastic

Clear Plastic

Mounting

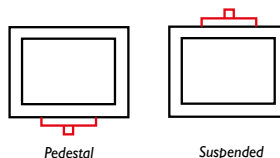

Pedestal

Suspended