

# Heavy Duty Work Lights

## ABL 500 LED 2000

- designed to exceed everyday demands in all applications
- stringent engineering and testing practices
- highest efficiency and durability in the harshest conditions



**ABL**  
lights group

**Premium lighting solutions**



## Heavy Duty - Work Lights

# ABL 500 LED 2000

The ABL 500 LED series work lights are designed to exceed everyday demands in all applications. Through stringent engineering and testing practices, we ensure the highest efficiency and durability in even the harshest operating conditions.

## Dimensions

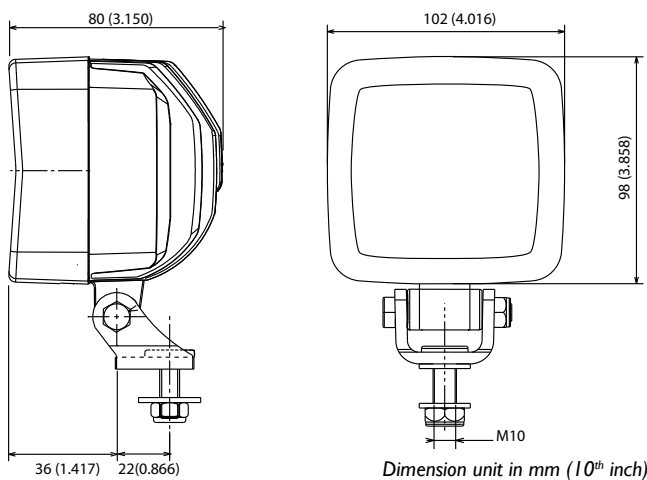

## Light Patterns

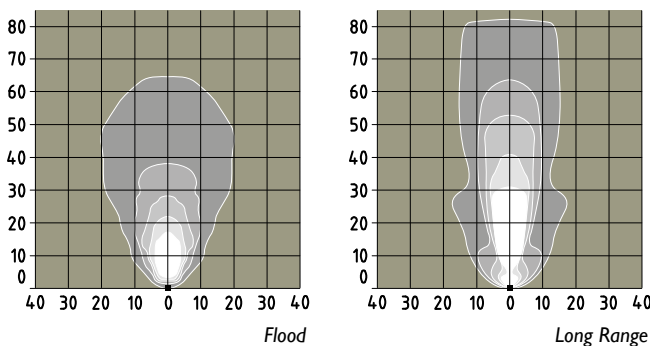

## Specifications

Bulb:	6 LED - 2000 Lumen
Lifetime:	20 000 hours
Color temperature:	6000K
Light pattern:	Flood, Long Range
Consumption:	28W
Voltage:	Multi 12-100V
Intensity:	1,2 Amp @ 24V
Weight:	0,9 Kg
Vibration resistance:	15 Grms from 24 to 2000Hz
Shock resistance:	60 G
EMC:	ISO 13 766 - ISO 14 982 - ISO 12 895
Load Dump:	130V continuous 200V 100 ms 1800V 50 μs
Polarity:	no polarity
Electronic Thermal Management:	full output @ +35°C ambient 20% dimmed @ +50°C ambient
Water Tightness:	IP 68 - IP 69K
Operating Temp:	-40°C to +85°C
Salt Spray:	ISO 9227
Lens:	hardened glass
Reflector:	free form reflector
Warranty:	20 000 operating hours or 4 years

## Connection



Built-in AMP 2 ways

Built-in DT 2 ways

## Options

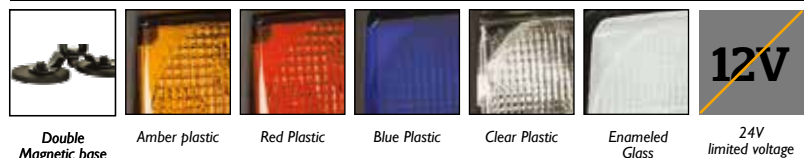

## Mounting

