

3800 LED

- full LED combination drive light
- ECE homologated
- 5 functions integrated
- easy one to one halogen replacement



ABL

OE Approved
Heavy Duty Lighting Product



3800 LED

The 3800 LED combination drive light is an ECE approved full LED product designed for on-road and off-road vehicles. Along with numerous mounting operations, the high vibration performance of this full LED combination light allows industrial vehicles to endure extreme working conditions with virtual-free maintenance for their homologated driving lights package.

Dimensions

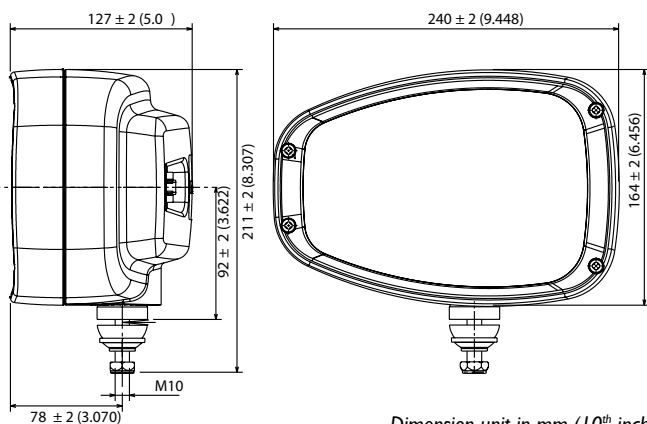

Dimension unit in mm (10th inch)



Specifications

Bulb	full LED modules
Lifetime	20 000 hours
Color temperature	6000°K
Light pattern	ECE R112 High / Low Beam ECE R6 Turn Signal and Repeater ECE R7 PiLot Light
Consumption	22W High Beam, 32W Low Beam
Voltage	Multi 12-24V
Intensity	1,29 Amp @ 24V (Low Beam) 0.85 Amp @ 24V (High Beam)
Weight	1,95 Kg
Vibration resistance	15 Grms from 24 to 2000Hz
Shock resistance	60 G
EMC	ISO 13 766 - ISO 14 982 - ISO 12 895 - CISPR25 Class3
Load Dump	36V continuous 72V 100 ms 1800 V 50 µs
Polarity	protected against reverse voltage
Electronic Thermal Management	protected against over heating
Water Tightness	IP 68 - IP 69K
Operating Temp	-40°C to +85°C
Salt Spray	ISO 9227
Lens	hardened glass
Reflector	free form reflectors and aspherical lenses modules
Warranty	20 000 operating hours or 4 years

Connection



Built-in DT
6 ways

Cable
compression seal
PGI I

Mounting

