

Normale Anwendung USUAL APPLICATION

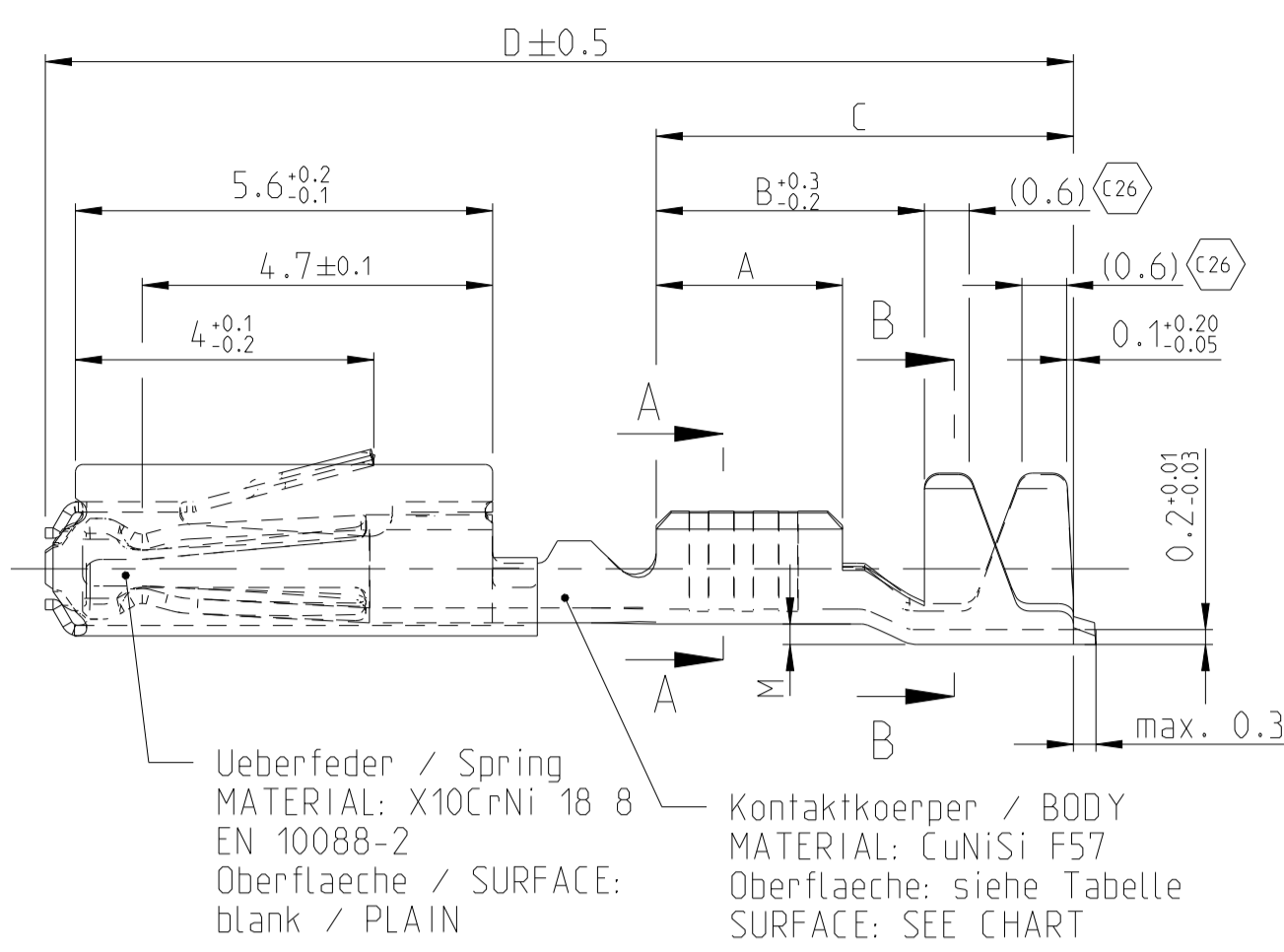

Ueberfeder / Spring
 MATERIAL: X10CrNi 18 8
 EN 10088-2
 Oberflaeche / SURFACE:
 blank / PLAIN

Kontaktkoerper / BODY
 MATERIAL: CuNiSi F57
 Oberflaeche: siehe Tabelle
 SURFACE: SEE CHART

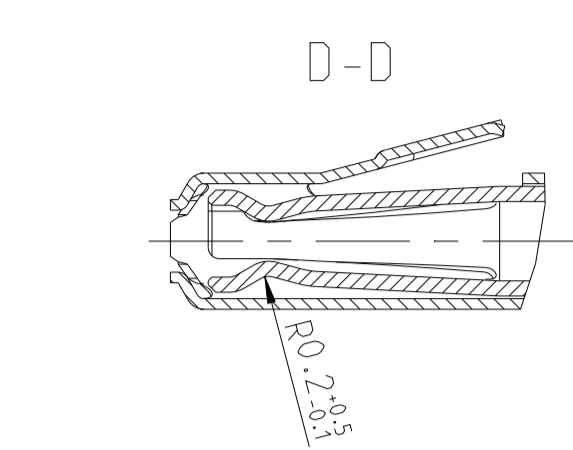
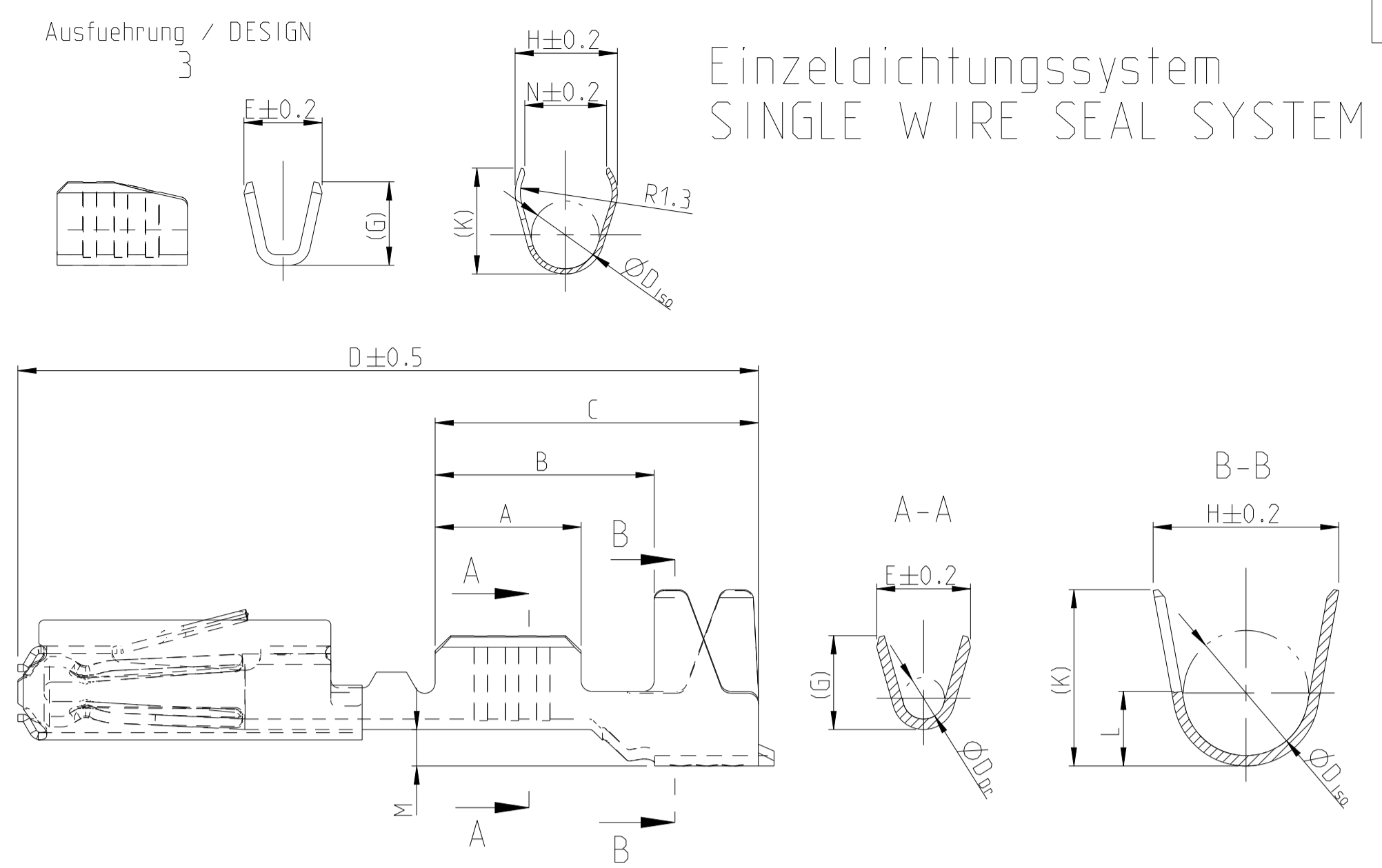
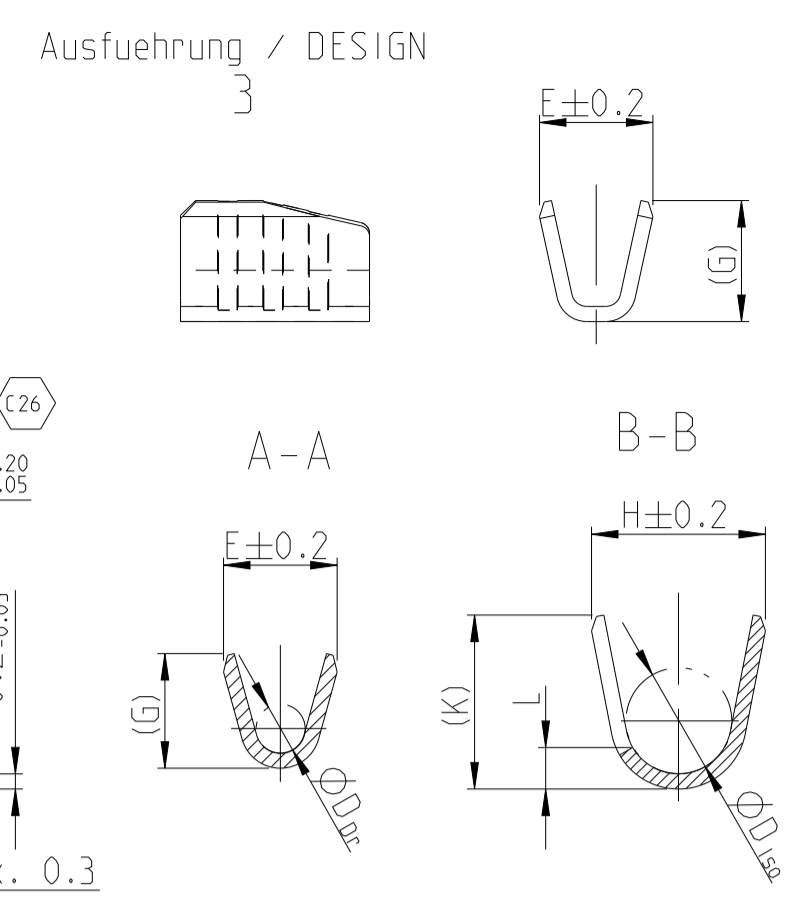

LOC	DIST	REVISIONS			
A1	-	NO.	DATE	BY	APPV
		C23	30APR2019	FRAN BERG	
		C24	09DEC2019	MAH. BERG	
		C25	28AUG2020	MAH. BERG	
		C26	20AUG2021	FRAN BERG	

versilberte/vergoldete Ausfuehrung SILVER/GOLD VERSION

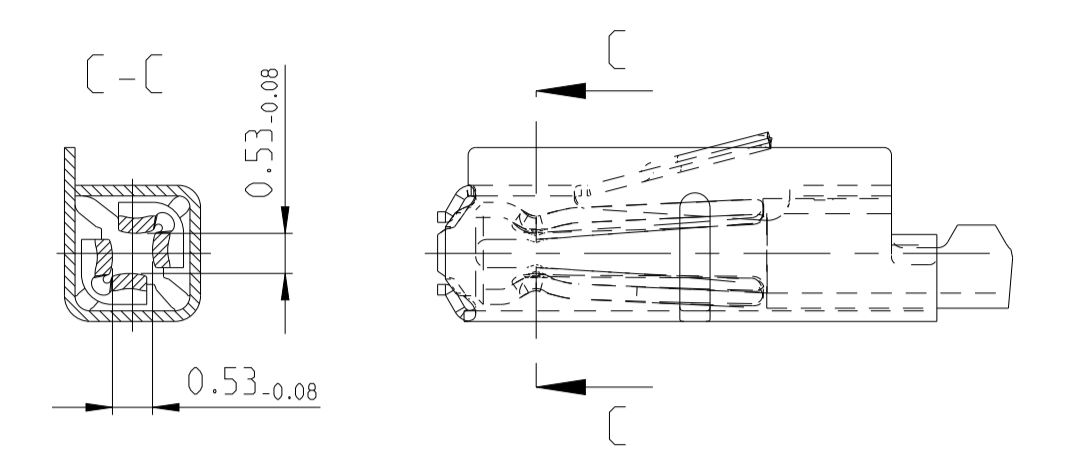

GEL VERSION

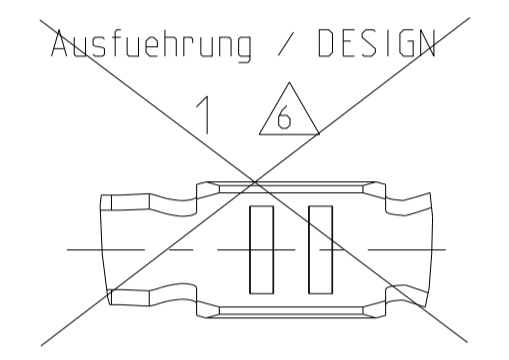
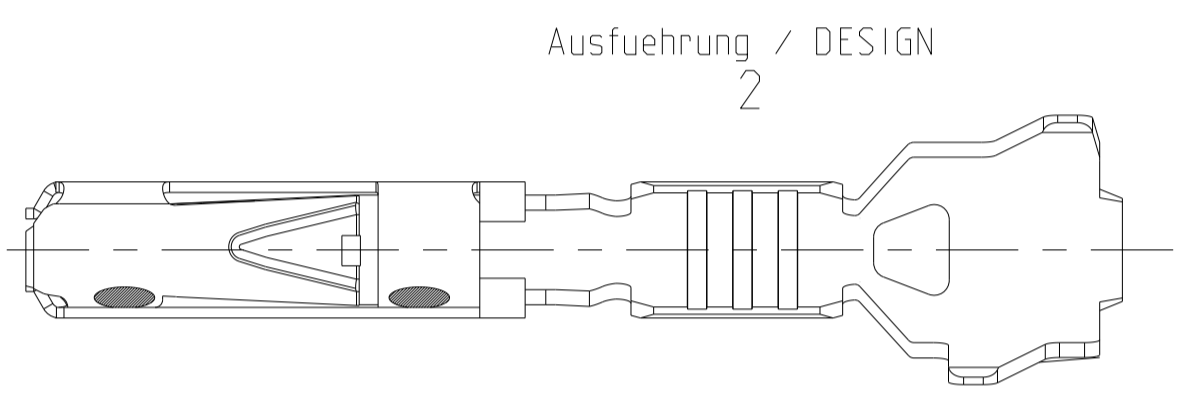
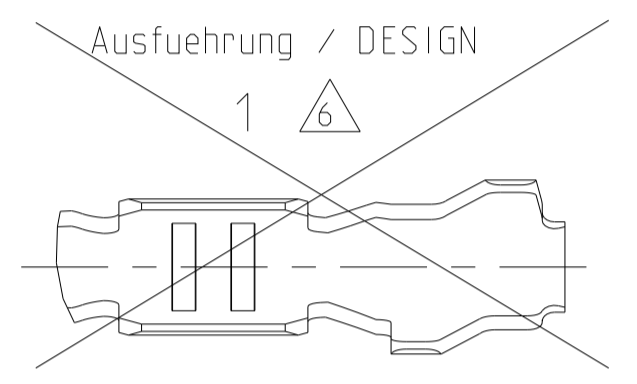
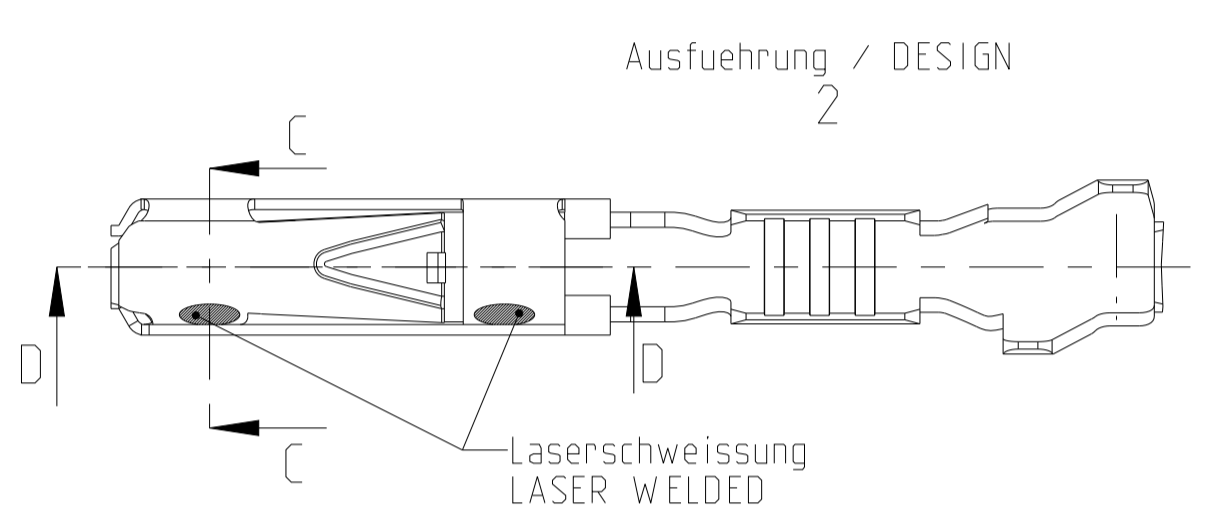
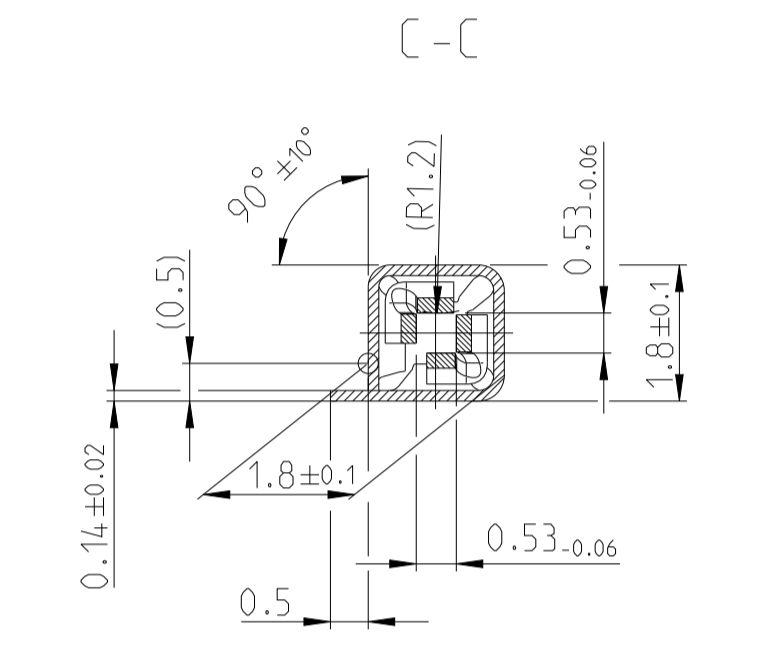
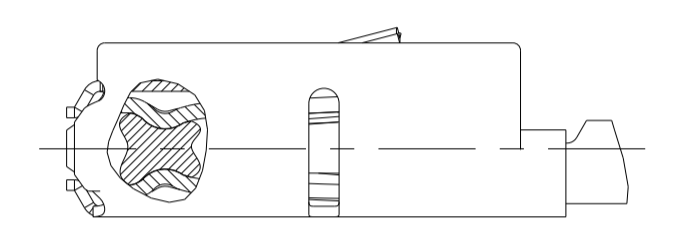

Oberflaeche / FINISH

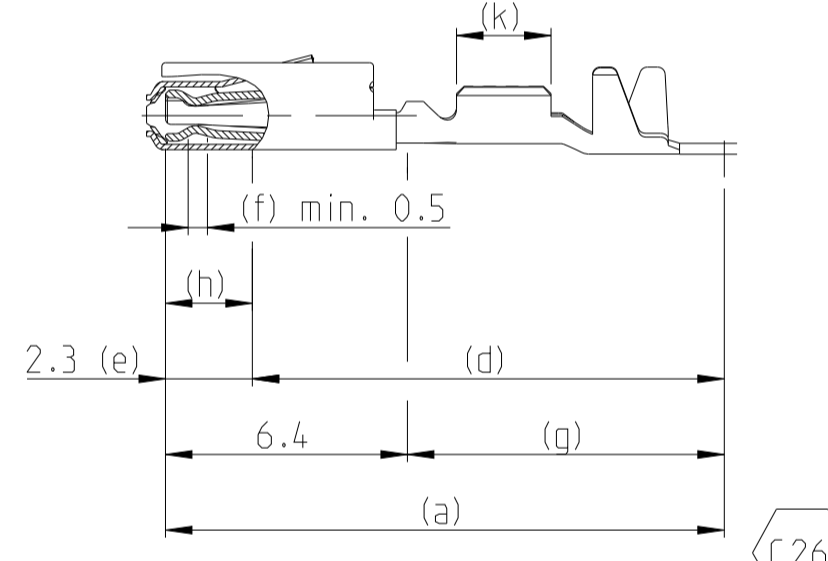

Sn: verzinnete Ausfuehrung
 TINNED
 (a) Kontaktkoerper: 0.8 - 2 µm Sn
 BODY: 0.8 - 2 µm Sn

Ag: versilbert
 SILVER
 (e) min. 0.3 µm Ag
 (f) min. 2.8 µm Ag INSIDE
 min. 2.8 µm Ag innen
 (g) min. 0.2 µm Sn
 (k) min. 0.8 - 2 µm Sn

Au (galvanisch): galvanisch vergoldet
 GOLD-ELECTROPLATED
 (d) 0.05-1 µm Ni, beidseitig
 0.05-1 µm Ni, ON BOTH SIDES
 (e) 1-3 µm Ni, beidseitig
 1-3 µm Ni, ON BOTH SIDES
 (f) min. 1.8 µm Au ueber (e), innen
 MIN. 1.8 µm Au OVER (e), INSIDE
 (g) min. 0.2 µm Sn ueber (d), beidseitig
 MIN. 0.2 µm Sn OVER (d), ON BOTH SIDES
 (h) Au galvanisch aufaufend
 Au OVERPLATING
 (k) min. 0.8 - 2.0 µm Sn

Bemerkungen

- Datumscode (Woche/Jahr z.B. KW 38/Jahr2009) und TE-Revision (z.B. Rev.A) DATE CODE (WEEK/YEAR E.G. WEEK NUMBER 38/YEAR2009) AND TE REVISION (E.G. REV. A)
- Passend zu Stiftkontakt siehe Zeichnung 929453 SUITABLE FOR PIN CONTACT SEE DRAWING 929453
- Einzelheiten der Ausfuehrung bleiben dem Hersteller ueberlassen DETAILS OF DESIGN ARE LEFT TO MANUFACTURER
- Nur fuer FLR-Leitung nach DIN 72551 Teil 6 FOR FLR-CONDUCTOR ACCORDING TO DIN 72551-6 ONLY
-
- nicht fuer Neuanwendung NOT FOR NEW APPLICATION
- zugverstaerkte Leitung nach LV 112-4 REINFORCED WIRE ACCORDING LV 112-4
- Bei doppelt fallenden Werkzeugen wird die erste Ueberfeder mit einer Kennzeichnung "-" versehen WITH DOUBLE OUT DIES THE FIRST SPRING WILL BE PROVIDED WITH AN INDICATION "-"
- Varianten von Design1 werden durch die entsprechenden Versionen von Design2 ersetzt VARIANTS OF DESIGN1 ARE SUPERSEDED BY CORRESPONDING VERSIONS OF DESIGN2

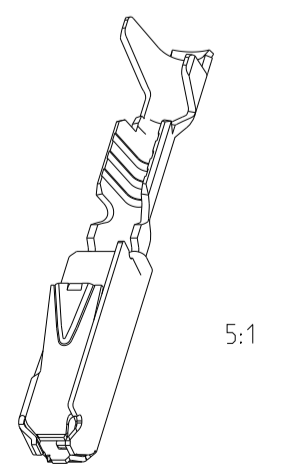
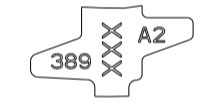

Part No.	Rev.	Material	Finish	Dimensions	Weight	Notes
6-965906-5	E	Au-Gel	C26	A = 2.8, B = 4.2, C = 6.2, D = 14.3, M = 0.7	E = 2, G = 2.1, DDr = 1	H = 3.5, K = 3.4, L = 1.5, D150 = 2.4
5-965906-6	D	Ag		A = 2.5, B = 3.9, C = 5.9, D = 14, M = 0.7	E = 1.8, G = 1.8, DDr = 0.8	H = 3.5, K = 3.4, L = 1.5, D150 = 2.4
5-965906-5	E	Au		A = 2.5, B = 4.3, C = 6.2, D = 14.2, M = 0.6	E = 1.5, G = 1.4	H = 4, K = 3.9, N = 3.1, D150 = 2.6
5-965906-1	D	Sn		A = 2.5, B = 3.6, C = 5.6, D = 13.7, M = 0.2	E = 2, G = 2.1, DDr = 1	H = 2.7, K = 2.9, L = 0.7, D150 = 1.6
5-962885-6	J	Ag		A = 2.5, B = 3.6, C = 5.6, D = 13.7, M = 0.2	E = 1.8, G = 1.8, DDr = 0.8	H = 2.3, K = 2.3, L = 0.6, D150 = 1.4
5-962885-5	K	Au		A = 2.5, B = 3.7, C = 5.4, D = 13.7, M = 0	E = 1.5, G = 1.5, DDr = 0.65	H = 2, K = 2, D150 = 1.1
5-962885-1	J	Sn		A = 2.5, B = 3.7, C = 5.4, D = 13.7, M = 0	E = 1.5, G = 1.5, DDr = 0.65	H = 2, K = 2, D150 = 1.1

Bestell-Nr. / ORDER NO. DESIGN 2	Bestell-Nr. / ORDER NO. DESIGN 3	Rev.	Bestell-Nr. / ORDER NO. DESIGN 1	Rev.	VERSION	DGB Wire Size Range mm ²	Oberflaeche SURFACE	Laenge LENGTH mm	Drahtcrimp WIRE CRIMP mm	Iso-crimp INSU-CRIMP mm	Gewicht WEIGHT g	Vergaehrung Spez. APPLICATION SPEC.	DGB Wire Size Range mm ²	Isolations Ø INSULATING DIA. mm	fuer Kammer Ø3.45 FOR CAVITY DIA. 3.45 mm	Blindstopfen RUBBER PLUG	fuer Kammer Ø4 FOR CAVITY DIA. 4 mm	Blindstopfen RUBBER PLUG
					normale Anwendung / USUAL APPLICATION	0.50-0.75	Au-Gel	114-18025										
					normale Anwendung / USUAL APPLICATION	0.25-0.35	Ag	114-18021										
					normale Anwendung / USUAL APPLICATION	0.13 / 0.17	Ag											
					normale Anwendung / USUAL APPLICATION	0.08-0.22	Ag											

zugehoerige Einzeldichtung / SUITABLE SINGLE WIRE SEAL

THIS DRAWING IS A CONTROLLED DOCUMENT. DWG: S. Garcia 05JAN1999, CHK: M. Bleicher 05JAN1999, R. Jetter 13AUG2003, APPV: M. Bleicher 13AUG2003

TE Connectivity

QMS
 Tabellenzeichnung Buchsenkontakt
 TABLE SOCKET CONTACT

114-18021 / 114-18025
 00779 ©=929454

SCALE 10:1 SHEET 1 OF 1 REV C26