

## Bedienungsanleitung ABS/EBS Prüfstecker

Art. 805ABS

## Mode d'emploi pour fiche d'essai ABS/EBS

Art. 805ABS

## User guide Test plug ABS/EBS

Art. 805ABS



Art. 805ABS



# Bedienungsanleitung ABS/EBS Prüfstecker

Art. 805ABS

Leuchten die Dioden 1, 3 und 4?



Die Sicherung für den Hauptstrom (30) kontrollieren.

Wenn sie in Ordnung ist, dann die Masse an den Steckstiften 3 und 4 kontrollieren.



Die Zündung einschalten.  
Leuchtet die Diode 2?



Die Sicherung für die Zündung kontrollieren (15).



Den Schalter auf Stellung 1 drücken.  
Die Kontrolllampe ABS für Fehler am Anhänger muss leuchten.



Die Glühlampe kontrollieren.

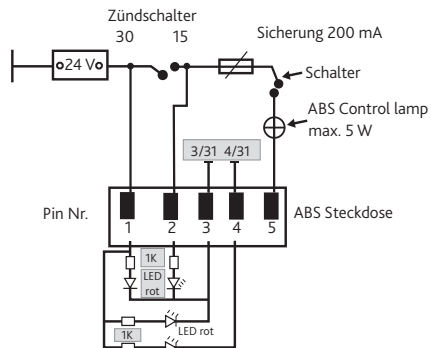
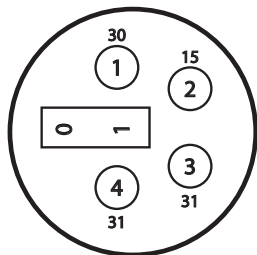

# Mode d'emploi Fiche d'essai ABS/EBS

Art. 805ABS

Est-ce que les diodes 1, 3 et 4 s'allument?



Contrôler le fusible du courant principal (30).

Si en ordre, contrôler la masse aux cosses 3 et 4.



Enclenchez l'allumage.  
Est-ce que la diode 2 s'allume?



Contrôler le fusible pour l'allumage (15).



Mettre l'interrupteur en position 1.  
La lampe de témoin ABS doit s'allumer.



Contrôler la lampe de témoin.

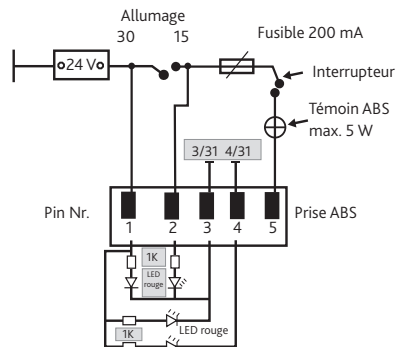
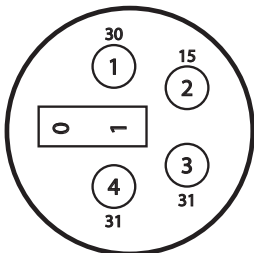

# User guide Test plug ABS/EBS

Art. 805ABS

Do the light diodes 1, 3 and 4 light up?



Check the main fuse (30).  
If it is OK, check the ground on the pins 3 and 4.



Turn on the ignition.  
Do the light diode 2 light up?



Check the ignition fuse (15).



Push down the switch to position 1.  
The control lamp must light up by error on the trailer.



Check the control lamp.

