

TECHNICAL DATA SHEET

Ref. 530020

Unipolar Power Relay

12VDC / 150A



GENERAL CHARACTERISTICS

Use: Continuous service
 Protection degree: IP65
 Weight: 0.55 Kg approx.
 Contacts: copper coated
 Connections: not polarized

FIELDS OF APPLICATION

Markets: industrial vehicles, handling vehicles, pleasure navy, industry...
 Particular applications: starting relay, preheating, motor control, power circuit...

CONTROL CIRCUIT

Connection: M5 terminals
 Tightening torque M5: 3.2/ 3.5 N.m
 Holding power: < 10 W
 Interlocking tension: > 9 VDC
 Disengaging tension: < 5 VDC

POWER CIRCUIT

Connection by M8 terminals
 Tightening torque: 12 / 13 N.m
 Type: normally opened unipolar
 Nominal intensity: 150 A
 Capacity: 600 A during 30 seconds
 Max. capacity: 800 A during 5 seconds
 Loading switch power: 50 A max.

PARTICULAR CHARACTERISTICS:

Black galvanised finishing.
 Corrosion test: 200 h salt spray resistance

Size diagrams:

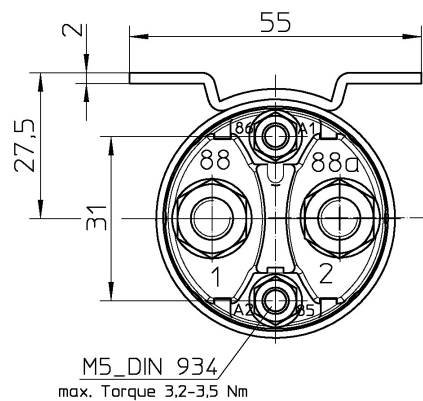
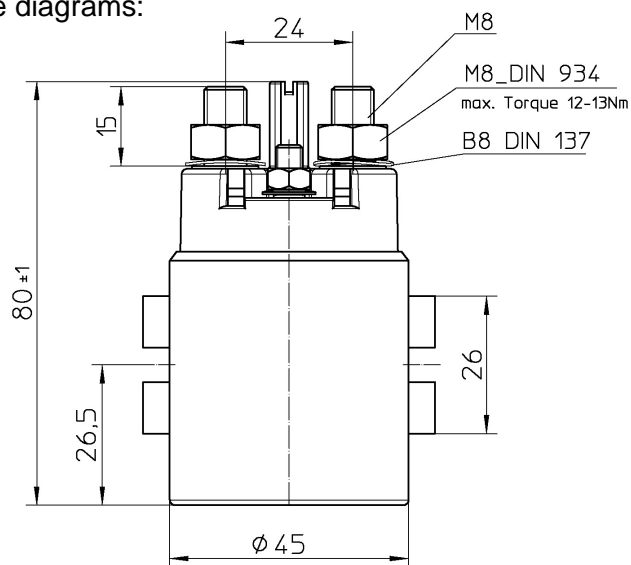

CIRCUIT:

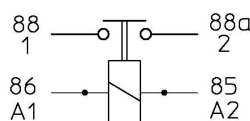

Mounting Dimension:

