

SEAL/MYLAR ASSEMBLY DETAIL

NOTES

1. THE MYLAR TAPE IS ONLY A CARRIER USED AS A PROCESS AID AND IS NOT PART OF THE FINAL HARNESS ASSEMBLY.
2. WHEN PARTS ARE SHIPPED, THEY MUST BE PACKED IN PLASTICS BAGS OR SHIPPING CONTAINERS MUST BE LINED WITH PLASTIC LINERS. BAGS OR LINERS MUST BE SEALED TO AVOID ENTRY OF FOREIGN MATTER.

OPTIONAL CONSTRUCTION 1
TYPE 103 ONLY

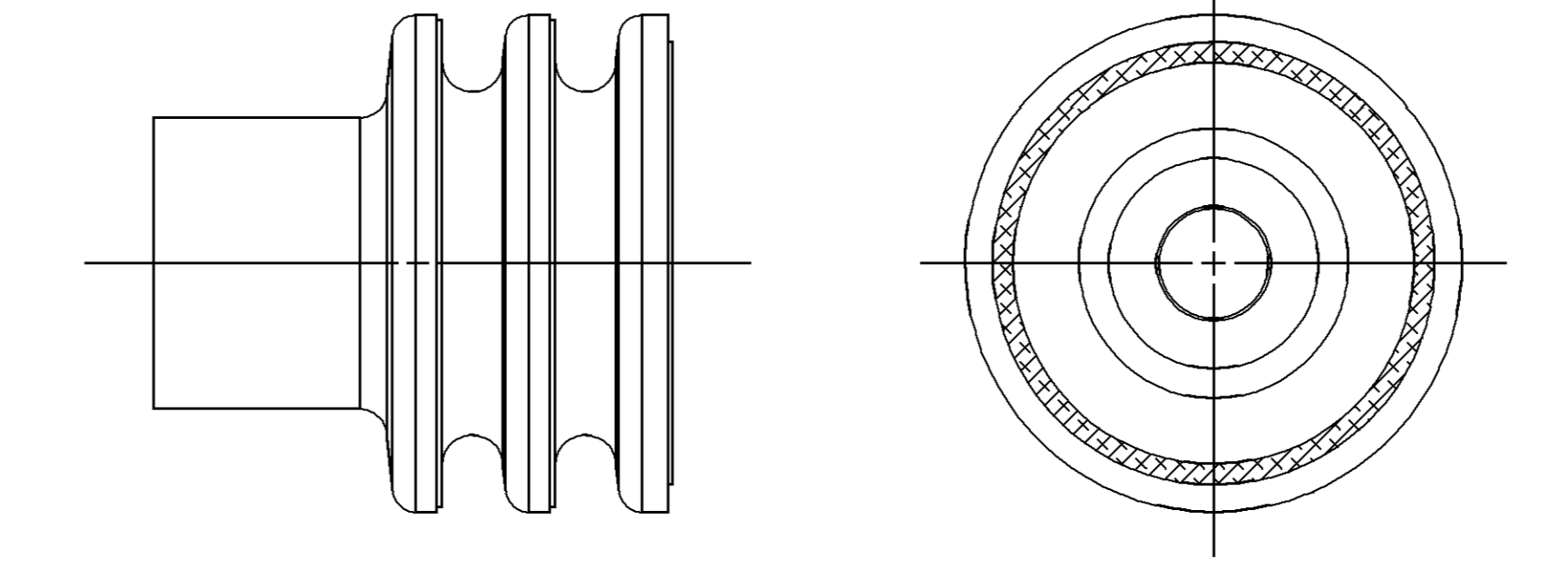
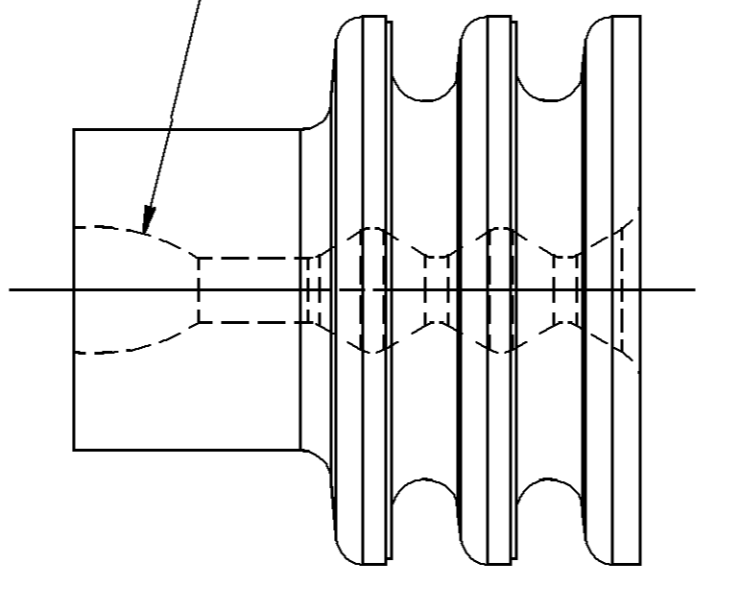

OPTIONAL CONSTRUCTION 2
(ANTI-STICK RING)

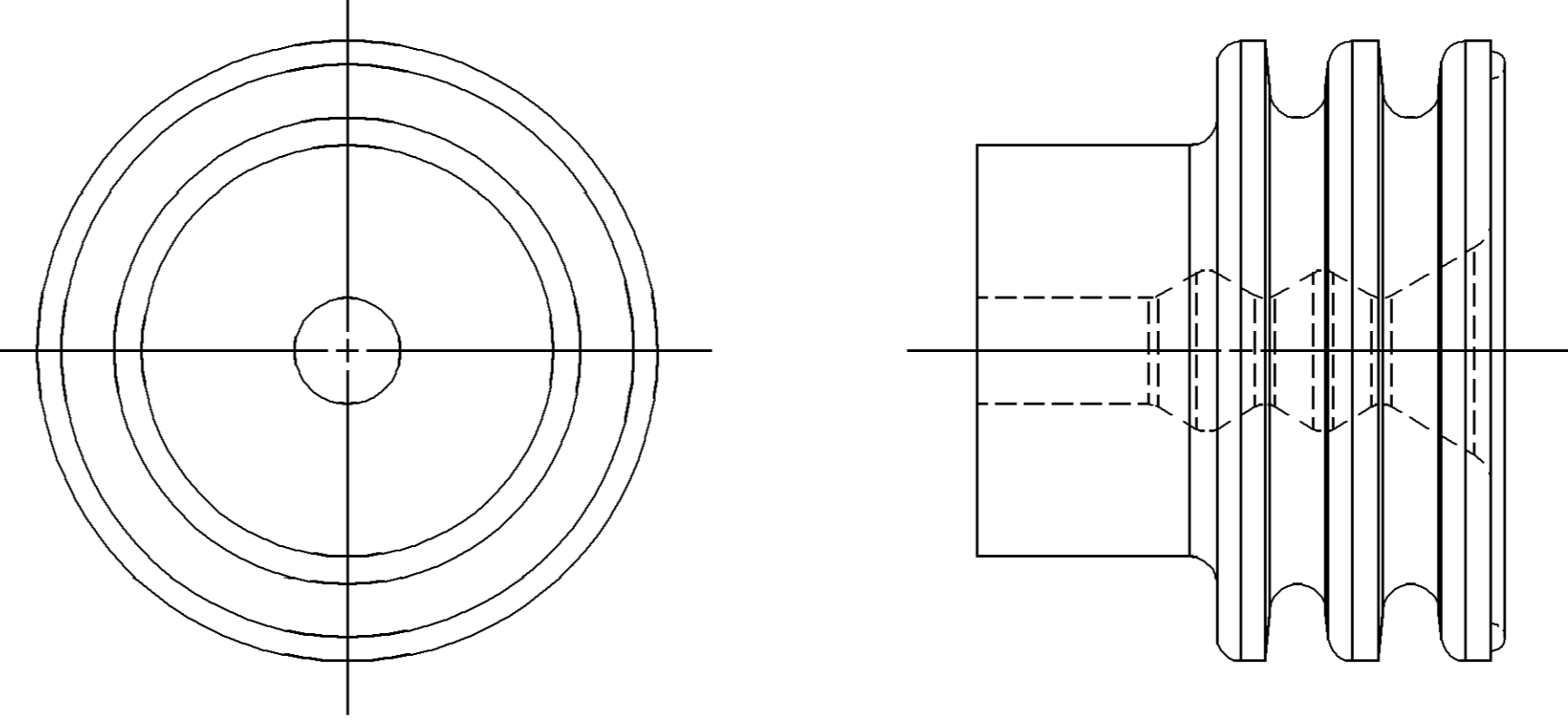

OPTIONAL CONSTRUCTION 3
THIS IS THE PREFERRED CONSTRUCTION FOR NEW TOOL BUILDS
(ANTI-STICK RING)

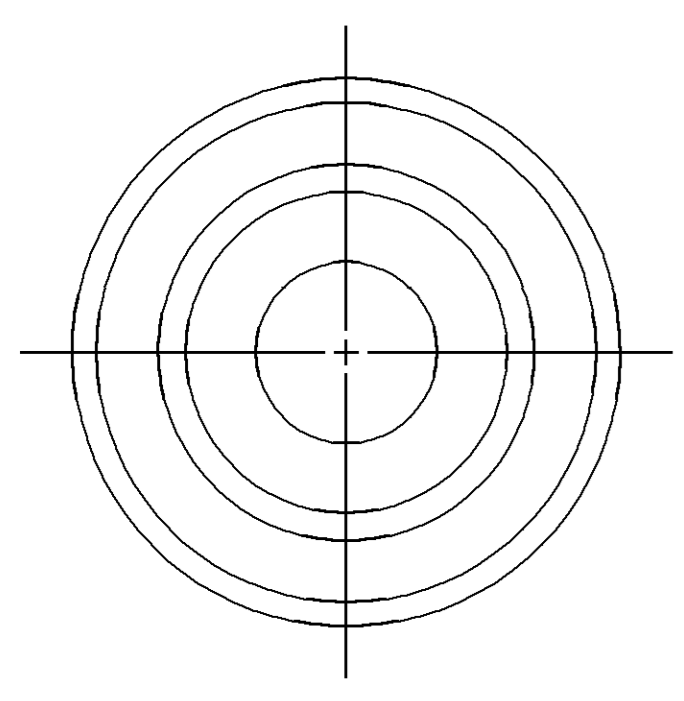

TYPE 102
SAME AS TYPE 101
EXCEPT FOR INTERNAL SEALING FEATURES

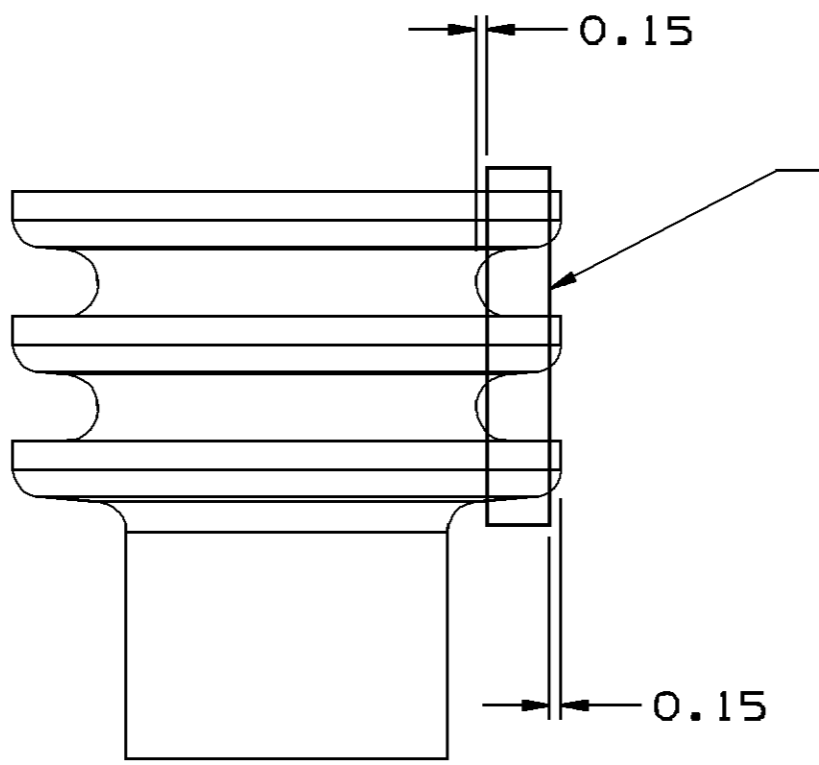
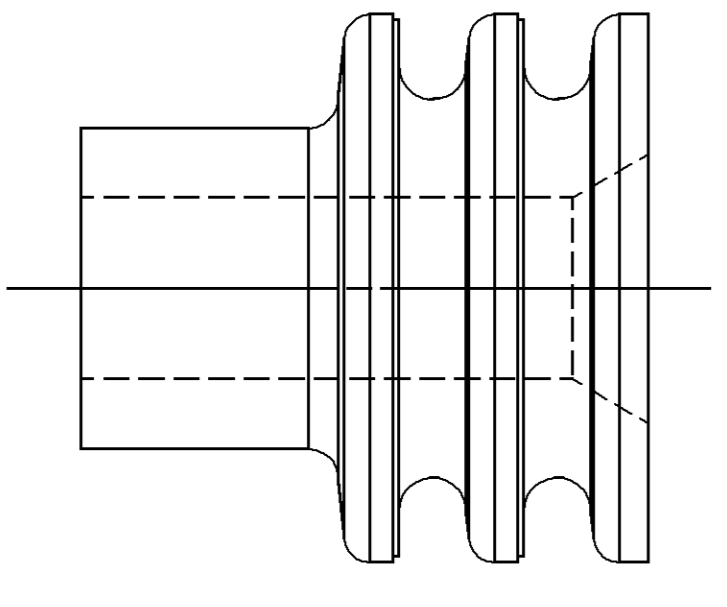

SEALING RIBS MUST BE FREE OF SINKS, VOIDS, KNIT LINES AND FLASH, IN THE AREA SHOWN ALL AROUND PART.
SEE VPS A-121 FOR ADDITIONAL INFORMATION

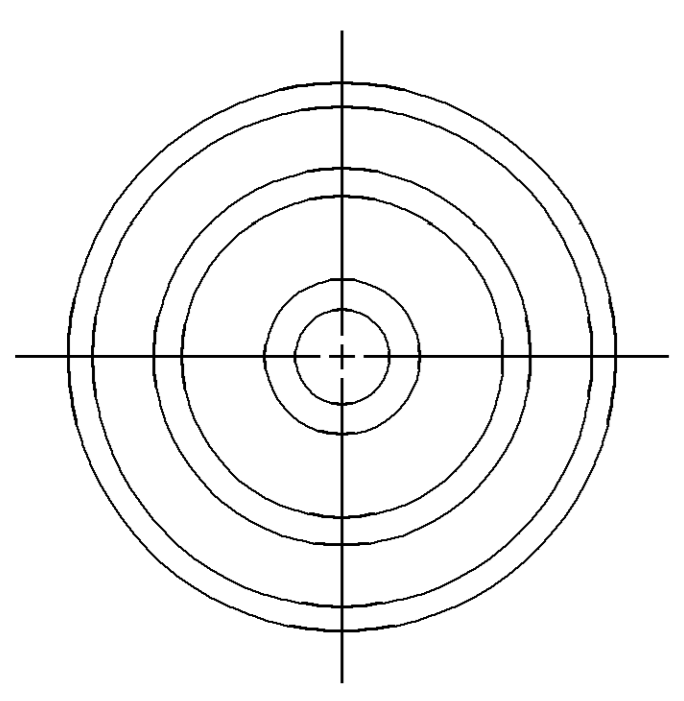

TYPE 103
SAME AS TYPE 101
EXCEPT FOR INTERNAL SEALING FEATURES

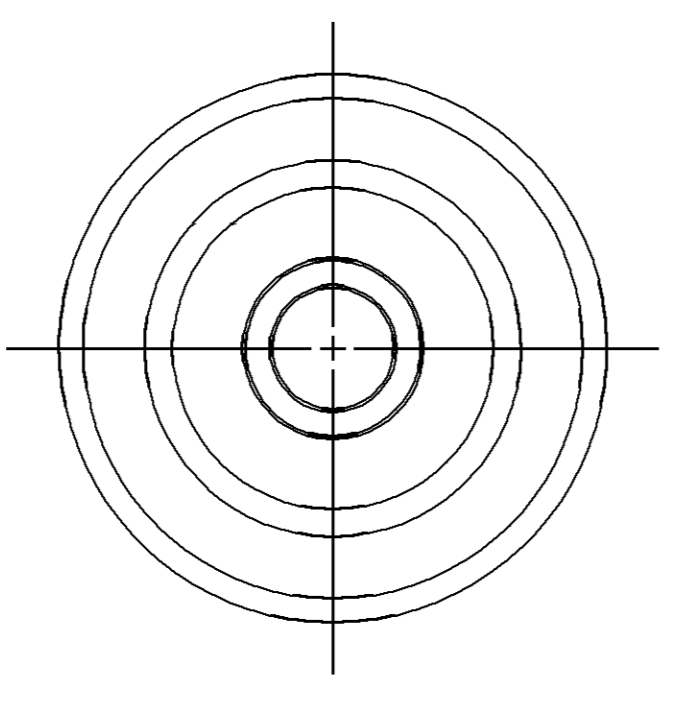
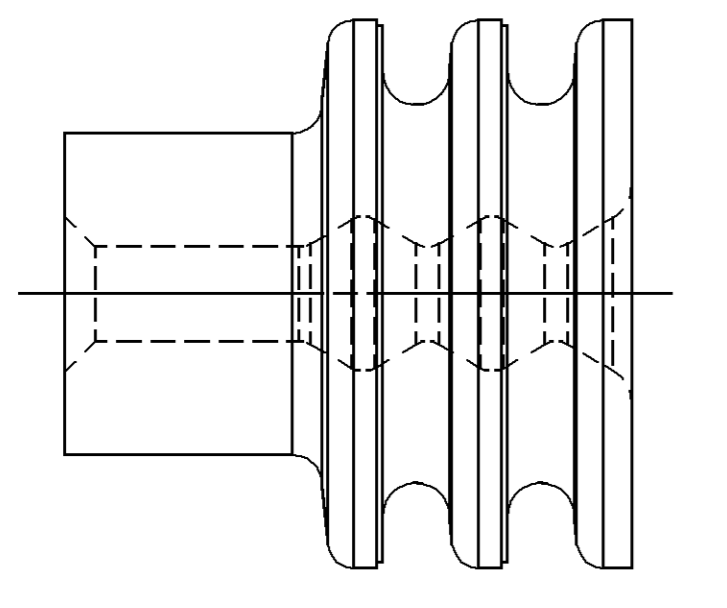

TYPE 101

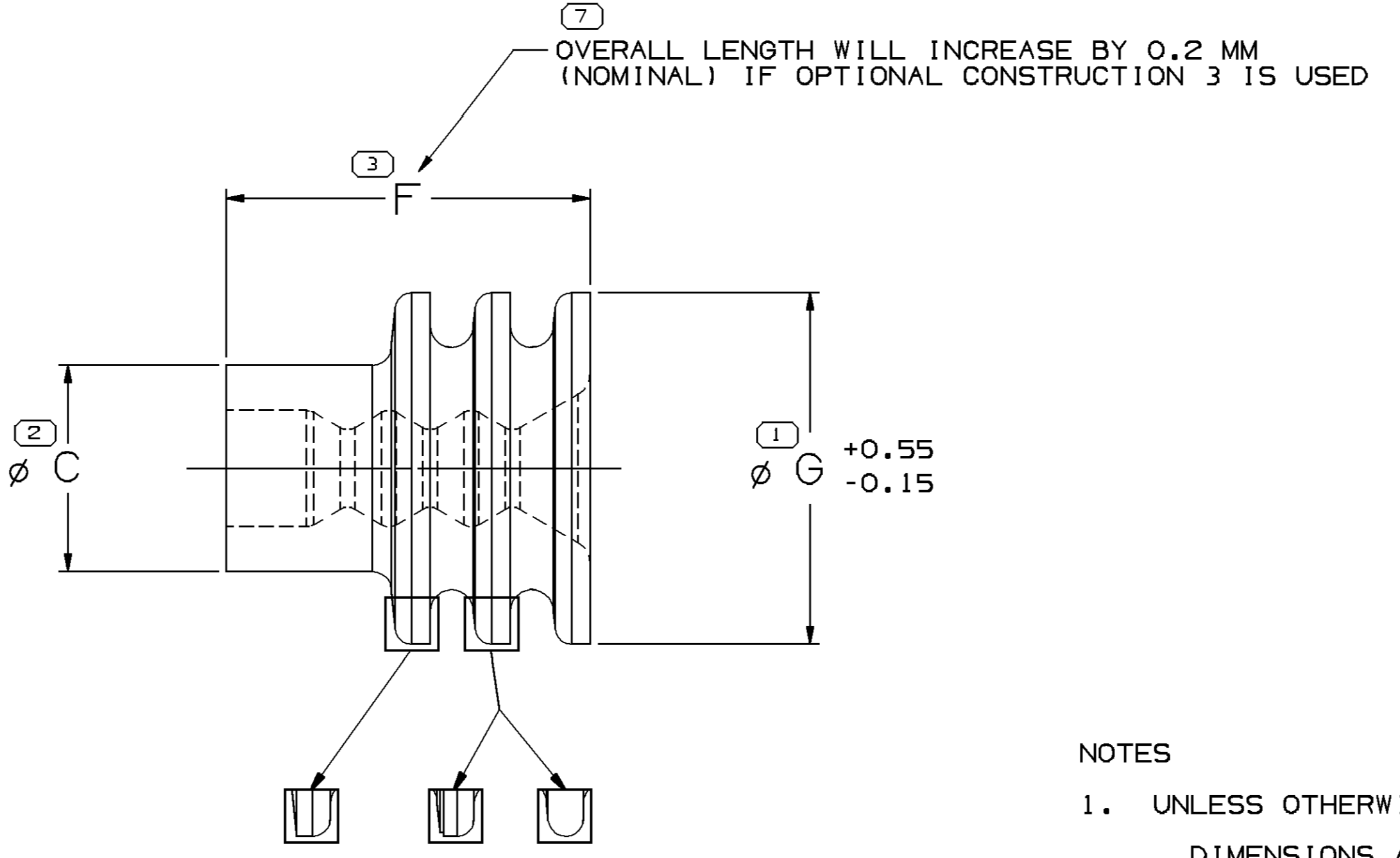

NOTES

1. UNLESS OTHERWISE SPECIFIED AND/OR INDICATED: DIMENSIONS ARE TO FACE OF VIEW SHOWN AND AUTOMATICALLY ROUNDED BY COMPUTER FOR INSPECTION (SEE MATH MODEL FOR PRECISE DIMENSIONS). FOR ALL OTHER DIMENSIONS NOT SHOWN BUT REQUIRED FOR TOOL BUILD, SEE MATH MODEL FOR PRECISE TOOL PATH DATA.
2. PARTS ARE TO BE PACKAGED IN SEALED PLASTIC BAGS. GROSS WEIGHT INCLUDING CARTON IS NOT TO EXCEED 34 POUNDS.
3. TO IMPROVE SEAL PROCESSING ON SLIPPERY OR SMOOTH CABLE INSULATION, THE APPLICATION ENGINEER MAY SPECIFY THE NEXT SMALLER SEAL SIZE P/N IN PLACE OF THE INDICATED SEAL FOR THE "CABLE O.D." LISTED IN THE CHART.
4. FOR P/N'S 12041351, 12041352 AND 15324984 ONLY, THESE SEALS RECOMMENDED FOR USE ON 1 MM² THIN WALL CABLE O.8 MM² REGULAR WALL ETFC CABLE.

SYMBOL DEFINITION		TOTAL NO OF INSPECTIONS REQUIRED	5
A	DIMENSION WITHOUT AN INSPECTION REPORT SYMBOL DOES NOT REQUIRE INSPECTION. IT MAY BE CONTROLLED ON THE INDIVIDUAL COMPONENT DRAWING.	5	
	LAST NO. USED	7	

MISSING SYMBOLS				REVISION HISTORY				AUTH	DR	AP/VD	AP/VD
DATE	STG	REV	N/P	CHG	ZONE						
150C99	R	001	-	-	-	CLEARED REV COLUMN & 12146012 - OBSOLETE	990003	JHN	JVM	LRT	
27JAO0	R	002	-	-	-	15324980 - 85 - RELEASED	000005	JLZ	GMC	RH	
07N000	R	003	-	-	-	15324980-85 - REVISED	202978	JLZ	EAR	JR	
10MR04	R	04	-	-	-	12010293, 12015193, 12015323, 12041351 & 12089679 REVISED PER NIN EWO BBL151 ALL PARTS - UPDATED MATERIAL SPECS	251237	RH	RH	MR	
21JN04	R	05	-	-	-	ADDED "ALTERNATE MATERIAL SPECIFICATION" TO CHART. ADDED PART NUMBERS 15497745-15497746, 15497754-15497755, AND 15497756-15497757.	256100	LLJ	LLJ	MR	
09MR05	R	06	-	-	-	12010293, 12015193, 12015284, 12015323, 12015359-60, 12015899, 12034365, 12041351-52, 12089444, 12089679, 15497745-46 AND 15497754-57 - RESTRICTED; 15324980-85 - MAT'L SPEC WAS M34661; ALL ACTIVE PARTS - REVISED NOTES AND REMOVED Ø C DIM FOR TYPE 102	265538	JBD	JAA	MR	
01FE06	R	07	-	-	-	UPDATED PDM ATTRIBUTES	276580	TS	TS	EJH	
22FE06	R	08	-	-	-	15324980-85 - MAT'L SPEC WAS M3469	276914	JBD	JVM	MPR	
03AU06	R	09	-	-	-	ALL ACTIVE PARTS - UPDATED MAT'L SPEC; ADDED ALTERNATE MAT'L SPEC, OPTIONAL CONSTRUCTION "3" & "2" VIEWS, SEALING RIBS VIEWS, OVERALL LENGTH NOTE & SEALING SURFACE NOTE AND DIMS (2PLCS); REMOVED OPTIONAL CONSTRUCTION VIEWS AND REVISED TOLERANCE DIM G	283299	JBD	FRG	MPR	
030C06	R	10	-	-	-	ALL ACTIVE PARTS - REMOVED INSPECTION SYMBOLS NUMBER 4 & 51; REVISED PROCESS SENSITIVE DIM AND SEALING RIBS LABEL	284959	JBD	FRG	MPR	
08JAO7	R	11	-	-	-	15363991, 15363980, 15338470 & 10717459 - ADDED PART NUMBERS AS MYLAR ASSEMBLIES	400035	JTV	FRG	MPR	

PART NO	REV	N/P	STATUS	PART NO	REV	N/P	STATUS	TYPE	MATERIAL SPECIFICATION	COLOR (REF ONLY)	ALTERNATE MATERIAL SPECIFICATION	CABLE O.D. ±0.05 SEE NOTE 3	C	F	G	CAVITY I.D.	VOL	EQUIVALENT CABLE SEAL
15497757	01	AC	RESTRICTED	15497756	01	AC	RESTRICTED	103	M2261009	PPL	-	2.15-1.6	4.25	7.5	7.25	6.7	0.164	12089679
15497755	01	AC	RESTRICTED	15497754	01	AC	RESTRICTED	102	M2261012	GRA	-	3.49-2.81	4.25	7.5	7.25	6.7	0.142	12010293
15497746	01	AC	RESTRICTED	15497745	01	AC	RESTRICTED	101	M2261001	GRN	-	2.85-2.03	4.25	7.5	7.25	6.7	0.15	12015323
15338470	B1	-	-	15324985	01	AH	-	103	M3469039	PPL	M3466039	2.15-1.6	4.25	7.5	7.25	6.7	0.164	12089679
-	-	-	-	15324984	01	AH	-	102	M3466038	TAN	M3466038	2.42-2.03	4.25	7.5	7.25	6.7	0.162	12041351
-	-	-	-	15324983	01	AH	-	103	M3469037	DK RD	M3466037	1.7-1.29	4.25	7.5	7.25	6.7	0.171	12015899
15363980	01	AA	-	15324982	01	AG	-	101	M3469007	GRN	M3466007	2.85-2.03	4.25	7.5	7.25	6.7	0.15	12015323
10717640	01	AA	-	15324981	01	AH	-	102	M3469008	BLU	M3466008	4.3-3.45	4.25	7.5	7.25	6.7	0.122	12015193
15363991	01	AA	-	15324980	01	AG	-	102	M3469003	GRA	M3466003	3.49-2.81	4.25	7.5	7.25	6.7	0.142	12010293
12146012	A1	-	OBSOLETE	12129930	C3	-	-	101	M4358005	ORN	-	2.85-2.03	4.15	7.3	7.25	6.7	0.142	-
12089444	B3	-	RESTRICTED	12089679	02	AD	RESTRICTED	103	M3471039	PPL	M2261009	2.15-1.6	4.25	7.5	7.25	6.7	0.164	15324985
-	-	-	-	12089443	B2	-	OBSOLETE	103	M2261006	YEL	-	2.15-1.6	4.25	7.5	7.25	6.7	-	-
12041352	A3	-	RESTRICTED	12041351	02	AD	RESTRICTED	102	M2261029	TAN	M2261029	2.42-2.03	4.25	7.5	7.25	6.7	0.162	15324984
12034365	A3	-	RESTRICTED	12015899	D6	-	RESTRICTED	103	M3471037	DK RD	M2261019	1.7-1.29	4.25	7.5	7.25	6.7	0.171	15324983
12015284	A3	-	RESTRICTED	12015323	04	AD	RESTRICTED	101	M3471007	GRN	M2261001	2.85-2.03	4.25	7.5	7.25	6.7	0.15	15324982
12015360	A3	-	RESTRICTED	12015193	03	AD	RESTRICTED	102	M3471008	BLU	M2261008	4.3-3.45	4.25	7.5	7.25	6.7	0.122	15324981
12015359	A3	-	RESTRICTED	12010293	11	AD	RESTRICTED	102	M3471003	GRA	M2261012	3.49-2.81	4.25	7.5	7.25	6.7	0.142	15324980
-	-	-	-	12010117	G2	-	OBSOLETE	101	M2261005	ORN	-	2.8-2.03	4.25	7.6	7.6	6.7	-	-

(1) PROCESS SENSITIVE DIMENSION

DIMENSIONS ENCLOSED IN () INDICATE REFERENCE DIMENSIONS AND NO TOLERANCE LIMITS ARE ESTABLISHED

DIMENSIONAL RANGE (MM) CHART E

FROM	0	> 20	> 30	> 70	> 100
TO	20	30	70	100	> 100

TOLERANCE UNLESS OTHERWISE SPECIFIED

ISO	151	±0.2	±0.3	±0.4	±0.5
ANGULAR	TOLERANCE	±2'			

ALL DIMENSIONS ARE IN MILLIMETERS

THIRD ANGLE PROJECTION

DO NOT SCALE

USE MATH DATA

UNIVERSITY MICROFILMS

DELPHI

DELPHI PACKARD ELECTRIC SYSTEMS
WARREN, OH

DATE

DR

AP/VD1 J. HOUGELMAN 13JAB9

AP/VD2 T. MUDREY 26JAB9

AP/VD3 A. HERMANN 31JAB9

AP/VD4

SUBSTANCES OF CONCERN AND RECYCLED CONTENT PER DELPHI 10949001

DRAWING NAME

TAXI SEAL CBL IW M/P

DRAWING NUMBER

12010295

SIZE A0 SCALE 10:1 FRAME NO 1 OF 2 SHEET NO 1576 REV N/P 1 OF 6 R 11