

M4x6 ISO 1207
max. Torque 2-2.2 Nm

MOUNTING DIMENSION

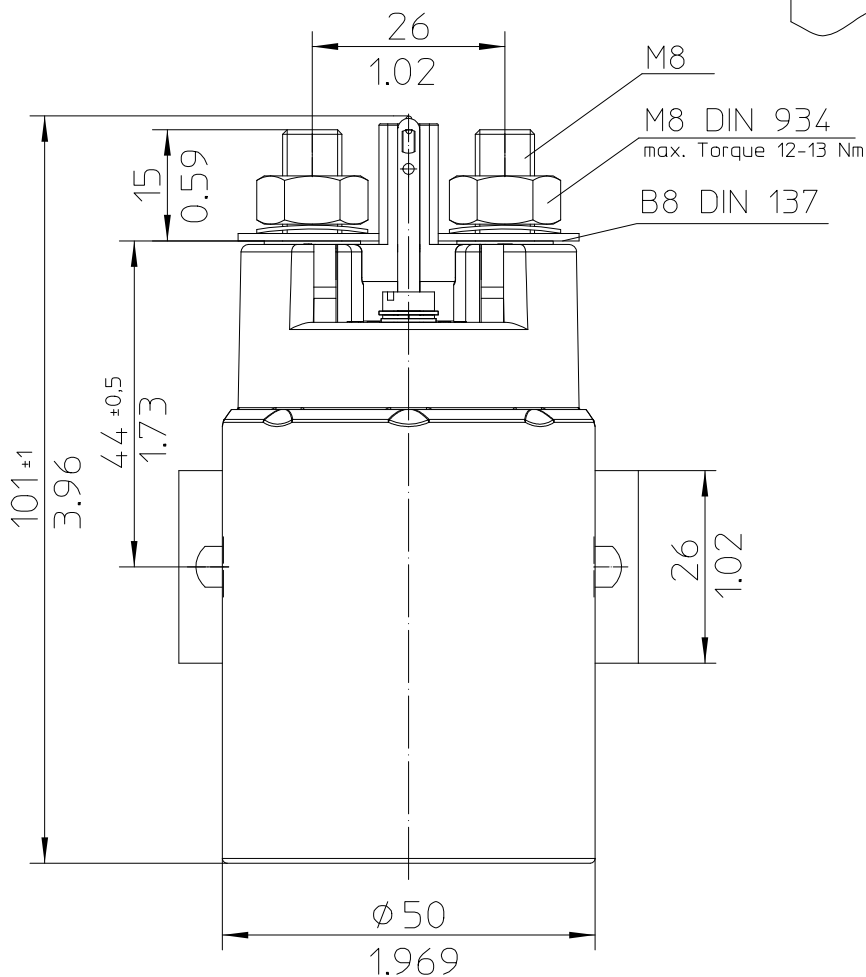

CIRCUIT

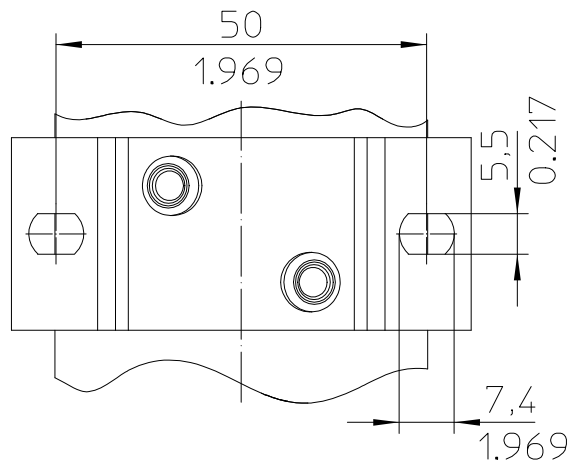
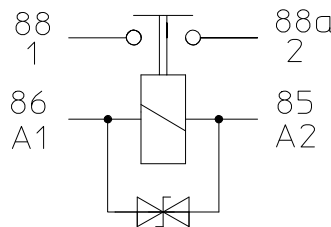

DIMENSIONAL TOLERANCES
3 PLACE DECIMAL ±0.010
2 PLACE DECIMAL ±0.03
ANGULAR ±0°30'

For this drawing we reserve the copyright in accordance with DIN ISO 16016

Third Angle Projection

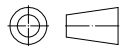

	Date	Name
Create	18.11.2014	Mielk
Edited	18.09.2019	Mielk
Check	19.09.2019	Kaise

mm Inch	Scale 1:1
General Tolerances DIN ISO 2768 cL	



Drawing No:

29-211-11

NSN:

